

# TRANSMISSION OIL COOLERS

## Technical Guide

### Ultra-Cool® Transmission Oil Coolers

The industry's first transmission cooler, the Ultra-Cool® transmission oil cooler is available in six sizes to fit a wide range of applications from sub-compacts to motorhomes.

#### FEATURES

- ULTRASONICALLY SOLDERED FOR RELIABILITY
- 100% PRESSURE TESTED AT 150 PSI FOR QUALITY ASSURANCE
- HIGH EFFICIENCY TURBULATORS IN EVERY TUBE FOR MAXIMUM HEAT DISSIPATION
- 3/8" PUSH-ON FITTINGS FOR QUICK AND EASY INSTALLATION

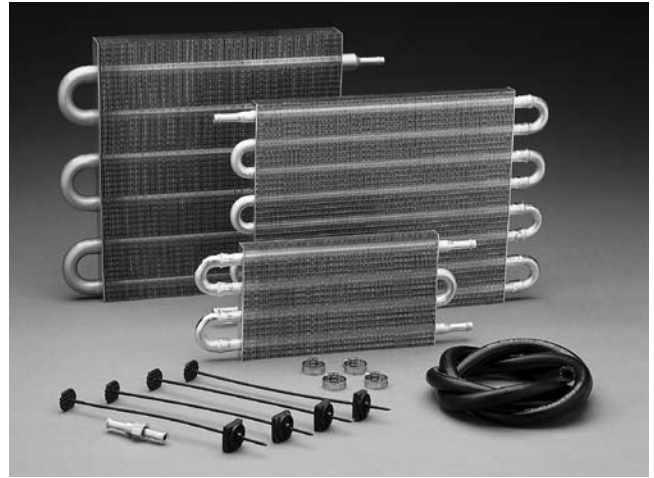

#### Ultra-Cool® Transmission Oil Coolers

PART #	THICKNESS	HEIGHT	LENGTH	CORE	FITTING SIZE	APPLICATION
401	3/4"	5"	12-1/2"	8-3/4"	3/8" PUSH-ON	SUB-COMPACT TO COMPACT CARS
402	3/4"	5"	15-7/8"	12-1/8"	3/8" PUSH-ON	UP TO FULL SIZE VEHICLES, TOWING UP TO 2,500 LBS.
403	3/4"	7-1/2"	12-1/2"	8-3/4"	3/8" PUSH-ON	UP TO FULL-SIZE VEHICLES, TOWING UP TO 2,500 LBS.
404	3/4"	7-1/2"	15-7/8"	12-1/8"	3/8" PUSH-ON	UP TO CLASS "C" MOTORHOMES, TOWING UP TO 5,000 LBS.
405	3/4"	10"	15-7/8"	12-1/8"	3/8" PUSH-ON	UP TO CLASS "A" MOTORHOMES, TOWING UP TO 10,000 LBS.
1015	1-1/2"	12"	15-1/8"	11-1/8"	3/8" PUSH-ON	TOWING WITH CLASS "A" MOTORHOME OR TOWING MORE THAN 10,000 LBS.

### Rapid-Cool® Transmission Oil Coolers

Rapid-Cool®'s unique plate and fin design offers excellent cooling efficiency in a compact, space-efficient design.

#### FEATURES

- 33% MORE EFFICIENT THAN A COMPARABLE TUBE AND FIN DESIGN
- PRE-DRILLED MOUNTING PLATES FOR EASY INSTALLATION
- FOUR SIZES AVAILABLE TO FIT A WIDER RANGE OF APPLICATIONS
- INTERNAL TURBULATION FOR EFFICIENT HEAT TRANSFER
- 3/8" PUSH-ON FITTINGS FOR QUICK AND EASY INSTALLATION



#### Rapid-Cool® Transmission Oil Coolers

PART #	THICKNESS	HEIGHT	LENGTH	CORE	FITTING SIZE	APPLICATION
676	3/4"	11"	6"	3-15/16"	3/8" PUSH-ON	COMPACT AND SUB-COMPACT CARS
677	3/4"	11"	7-1/2"	5-1/2"	3/8" PUSH-ON	UP TO FULL SIZE VEHICLES, TOWING UP TO 2500 LBS.
678	3/4"	11"	9-1/2"	7-3/8"	3/8" PUSH-ON	UP TO CLASS "C" MOTORHOMES, TOWING UP TO 5000 LBS.
679	3/4"	11"	11-5/8"	9-1/2"	3/8" PUSH-ON	UP TO CLASS "A" MOTORHOMES, TOWING UP TO 10,000 LBS.

#### IMPORTANT NOTES

- 1 DO NOT use transmission oil coolers for engine oil applications. Engine damage may result due to flow restrictions.
- 2 For extreme cold weather conditions (20°-30° below 0), recommended installation includes a #163 thermostatic bypass kit.

# TRANSMISSION OIL COOLERS

## Technical Guide

COOLERS



### High Performance Transmission Oil Coolers

Available in three sizes for medium to heavy duty applications, our high performance cooler is designed to provide outstanding cooling, as well as to complement other high performance accessories.

#### FEATURES

- SAE 45 DEGREE FITTINGS FOR MAXIMUM RELIABILITY
- ALL ALUMINUM LIGHTWEIGHT CONSTRUCTION
- ELECTROSTATICALLY POWDER COATED TO PREVENT CORROSION

### High Performance Transmission Oil Coolers

PART #	THICKNESS	HEIGHT	LENGTH	CORE	FITTING SIZE	APPLICATION
512	3/4"	7-1/2"	12-1/2"	8-3/4"	9/16"-18 S.A.E. FLARE	UP TO FULL SIZE VEHICLES, TOWING UP TO 2,500 LBS.
514	3/4"	7-1/2"	15-7/8"	12-1/8"	9/16"-18 S.A.E. FLARE	UP TO CLASS "C" MOTORHOMES, TOWING UP TO 5,000 LBS.
516	3/4"	10"	15-7/8"	12-1/8"	9/16"-18 S.A.E. FLARE	UP TO CLASS "A" MOTORHOMES, TOWING UP TO 10,000 LBS.

#### IMPORTANT NOTES

- DO NOT use transmission oil coolers for engine oil applications. Engine damage may result due to flow restrictions.
- For extreme cold weather conditions (20°-30° below 0), recommended installation includes a #163 thermostatic bypass kit.

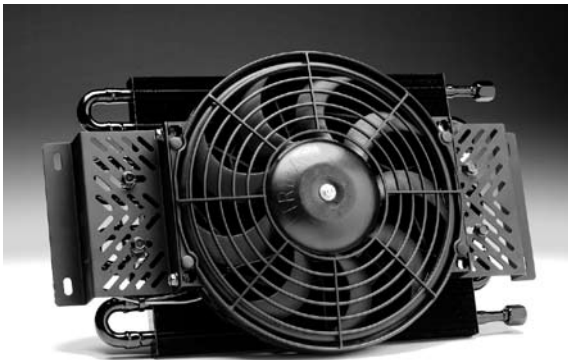

### Remote Transmission Oil Cooling Systems

Our remote mount cooling systems use the most advanced stator fans to evenly distribute airflow over the cooler surface for maximized cooling. Both units can be remotely mounted away from the radiator. Compatibility with model 3651 adjustable fan control, or can be operated with a manual switch (not included).

#### FEATURES

- Anodized brushed aluminum brackets.
- Remote mounting
- Fan and cooler preassembled
- Stator fan blade technology

525 — High Performance



526 — Rapid-Cool®

Use part number 125 or 126 Transmission Hose  
See page 71

### Remote Transmission Oil Cooling Systems

PART #	THICKNESS	HEIGHT	LENGTH	FITTING SIZE	APPLICATION
525	3.5"	11"	18.5"	9/16"-18 S.A.E. FLARE	THREADED COOLER FITTINGS FOR MAXIMUM DEPENDIBILITY.
526	3.5"	11"	13.8"	3/8" PUSH-ON	ULTRA COMPACT DESIGN PROVIDES SAME COOLING AS THE HIGH PERFORMANCE MODEL.

### Power Steering Oil Cooler

Our power steering oil cooler removes destructive heat generated within a power steering system, especially in vehicles with large tires such as, motorhomes and off-road vehicles. Installation of a power steering oil cooler will prolong the life of the system's pump, hoses, and seals.

PART #	THICK	HEIGHT	LENGTH	APPLICATION
1009	3/4"	2-1/2"	9"	VEHICLES WITH 3/8" I.D. POWER STEERING RETURN HOSE



### Ultra Cool® Engine Oil Coolers – Light Duty

LIGHTWEIGHT ALL ALUMINUM CONSTRUCTION  
 ULTRASONICALLY SOLDERED FOR MAXIMUM RELIABILITY  
 TURBULATORS IN EVERY TUBE FOR EFFICIENT COOLING  
 PART #462 SPECIALLY DESIGNED FOR CHEVROLET V8 ENGINES

PART #	THICK	HEIGHT	LENGTH	CORE	FITTING SIZE	APPLICATION
459	3/4"	7-1/2"	12-1/2"	8-3/4"	1/2" PUSH-ON	ALL EXCEPT CHEVY V8
462	3/4"	7-1/2"	12-1/2"	8-3/4"	1/2" PUSH-ON	CHEVY V8 ONLY



### Ultra Cool® Engine Oil Coolers – Medium Duty

TWO-PASS THIN-LINE HEADERED DESIGN FOR INCREASED COOLING  
 100% HAND-BRAZED CONSTRUCTION  
 TURBULATORS IN EVERY TUBE FOR EFFICIENT COOLING  
 PART #461 SPECIALLY DESIGNED FOR CHEVROLET V8 ENGINES

PART #	THICK	HEIGHT	LENGTH	CORE	FITTING SIZE	APPLICATION
457	3/4"	10"	12-1/4"	8-5/8"	3/8" FPT	ALL EXCEPT CHEVY V8
461	3/4"	10"	12-1/4"	8-5/8"	3/8" FPT	CHEVY V8 ONLY



### Swirl Cool® – Heavy Duty

COPPER HEADER AND TUBE CONSTRUCTION  
 INNER-SWIRL® TURBULATOR IN EVERY TUBE FOR MAXIMUM COOLING AND EFFICIENCY  
 VIBRATION ABSORBING RUBBER BLOCK MOUNTING  
 1-1/2" THICK HEADERED DESIGN FOR INCREASED COOLING AND EFFICIENCY  
 MINIMAL PRESSURE LOSS DUE TO HEADERED DESIGN  
 PART #1046 DESIGNED FOR CHEVROLET V8 ENGINES

PART #	THICK	HEIGHT	LENGTH	CORE	FITTING SIZE	APPLICATION
1040	1-1/2"	6-1/2"	18"	14-1/4"	1/2" FPT	ALL EXCEPT CHEVY V8
1046	1-1/2"	6-1/2"	18"	14-1/4"	1/2" FPT	CHEVY V8 ONLY



Chevrolet specific kits come with metal line kit to route oil lines past exhaust manifold. Refer to oil cooler application pages for specific year and model recommendations.

# HEAVY DUTY OIL COOLERS

## Application Guide

Designed for rugged heavy duty use, our coolers can be used for many different cooling applications, including transmission, engine, gear box, hydraulic oils, and diesel fuel.

Our heavy duty coolers feature brazed copper tubes with aluminum fin construction. Turbulators in every tube provide 3 1/2 times more cooling surface than bare tubing.

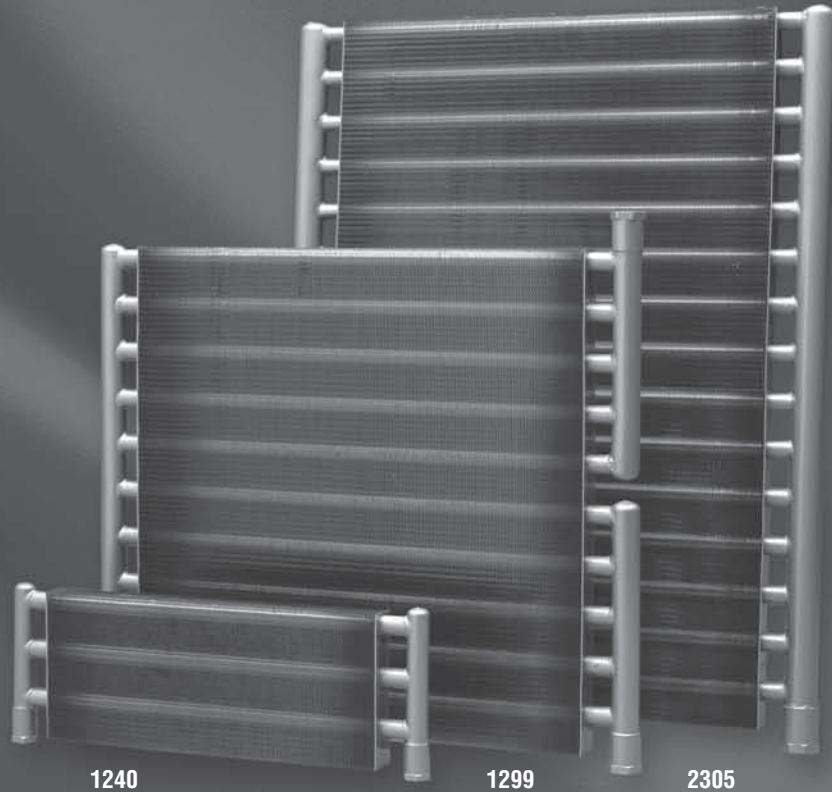

		HIGHWAY (1)	OFF-HIGHWAY
--	--	-------------	-------------

TRANSMISSION MODEL	GMP FLOW	HORSEPOWER	ADD-ON COOLER PART #	REPLACEMENT COOLER PART #	ADD-ON COOLER PART #	REPLACEMENT COOLER PART #
AT 540, 542 545	4.5 545	125	1268	1299	1299	1271
		150	1260	1299	1299	1271
		175-235	1299	1299	1299	1271
MT 40, 41, 42 SERIES	8.0	150	1260	1290	1290	1292
		200	1290	1290	1292	2305
		250	1290	1292	2305	2306
MT 643, 645, 653	8.0	175-200	1299	1299	1299	1271
		250	1299	1271	1271	2306
MT 644, 646, 647, 648, 654	12.0	200	1290	1290	1290	2305
MT 645CR, 655, 656CR		250	1292	1292	1292	2305
		300	1290	2305	2305	1297
HT 740, 747, 748, 750	15.0	250	1290	1292	1292	2306
HT 7500DR, 754, 755CR		300	1290	2305	2305	1297
HT 755DR, CBLT 754		350	1292	2306	2306	1298
		400	1292	1297	1297	1298
		425	2305	1298	1298	2312
V 730, 731	20.0	200	1290	1292	-	-

(1) Highway vehicles refers to vehicles usually operated above 30mph. Use off-highway applications for refuse trucks.

# HEAVY DUTY OIL COOLERS

## Technical Guide

### Heavy Duty Oil Cooler Specifications

PART #	MOUNTING PARTS		OVERALL SIZE HEIGHT, LENGTH, THICKNESS	NUMBER OF ROWS	NUMBER OF PASSES	FITTING SIZE FPT	GPM FLOW RANGE	COOLING BTU/HR.		PACKED WEIGHT IN POUNDS
	QTY.	P/N						@2500 FPM Airflow	@ 100°F ITD Oil To Air	
TWO-PASS COOLERS										
1233	1	210	10 x 12-1/4 x 3/4	1	2	3/8	2 – 10	7,300 – 12,000		4
1299	3	238	22-1/8 x 24 x 1-1/2	1	2	3/4	2.5 – 20	36,500 – 61,000		17
1271	2	238	26-3/4 x 30 x 1-1/2	1	2	1	3 – 12	49,300 – 89,600		26
ONE-PASS COOLERS										
1215	1	238	4-1/2 x 15 x 1-1/2	1	1	1/2	1 – 8	6,000 – 8,500		3
1234	2	238	6-1/2 x 15 x 1-1/2	1	1	1/2	1.5 – 12	9,000 – 12,800		4
1240	2	238	6-1/2 x 18 x 1-1/2	1	1	1/2	1.5 – 12	10,900 – 16,200		4
1236	2	238	8-1/2 x 18 x 1-1/2	1	1	1/2	2 – 16	14,500 – 21,500		6
1241	2	238	8-1/2 x 21 x 1-1/2	1	1	1/2	2 – 16	16,900 – 25,900		7
1268	2	238	12-3/4 x 18 x 1-1/2	1	1	3/4	3 – 24	21,200 – 31,200		8
1260	2	238	12-3/4 x 24 x 1-1/2	1	1	3/4	3 – 24	28,100 – 44,300		11
1284	3	238	16-3/4 x 24 x 1-1/2	1	1	3/4	4 – 32	37,500 – 59,000		14
1290	3	238	18-3/4 x 24 x 1-1/2	1	1	3/4	4.5 – 36	42,200 – 66,400		15
1292	3	238	25 x 24 x 1-1/2	1	1	1	6 – 48	55,200 – 86,400		20
2305	4	238	31 x 24 x 1-1/2	1	1	1	7.5 – 60	70,000 – 108,000		26
2306	4	238	31 x 30 x 1-1/2	1	1	1	7.5 – 60	83,600 – 139,800		32
1297	4	238	37-1/4 x 30 x 1-1/2	1	1	1-1/4	9 – 72	99,000 – 164,600		38
1298	4	238	37-1/4 x 40 x 1-1/2	1	1	1-1/4	9 – 72	122,600 – 226,100		51
2312	4	238	41-3/4 x 43 x 1-1/2	1	1	2	10 – 80	149,600 – 264,500		94
TWO-ROW COOLERS										
2271	4	238	20-1/4 x 24 x 3	2	1	1	9 – 36	89,900 – 114,300		38
2292	1	107	26-7/8 x 24 x 3	2	1	1	12 – 96	83,500 – 152,400		51
2297	1	183	45 x 42 x 3	2	1	2-1/2	18 – 144	235,900 – 415,700		134

# ENGINE OIL COOLERS

## Technical Guide

COOLERS

*Typical in series transmission oil cooler installation*

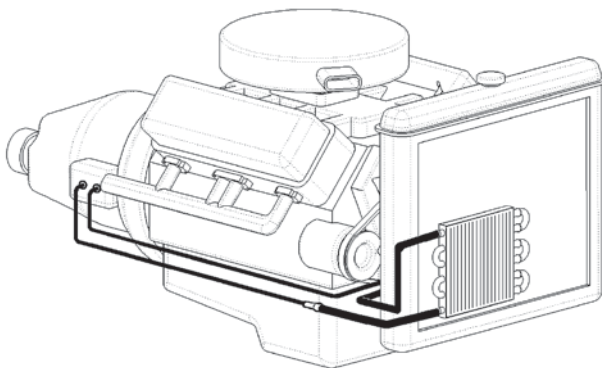

*Full flow engine oil cooler system with sandwich adapter*

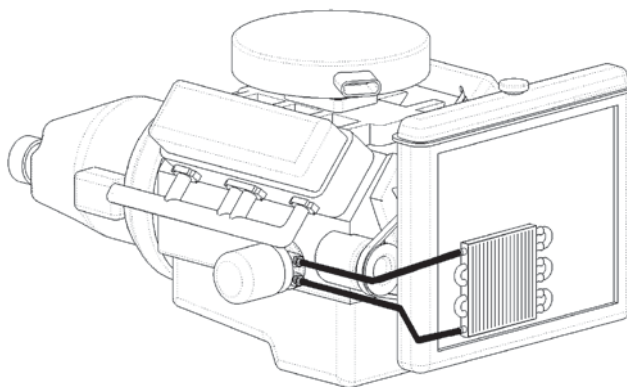

SHOWN ARE THE THREE SUGGESTED LOCATIONS FOR THE COOLER IN RELATION TO THE AIR CONDITIONER CONDENSER

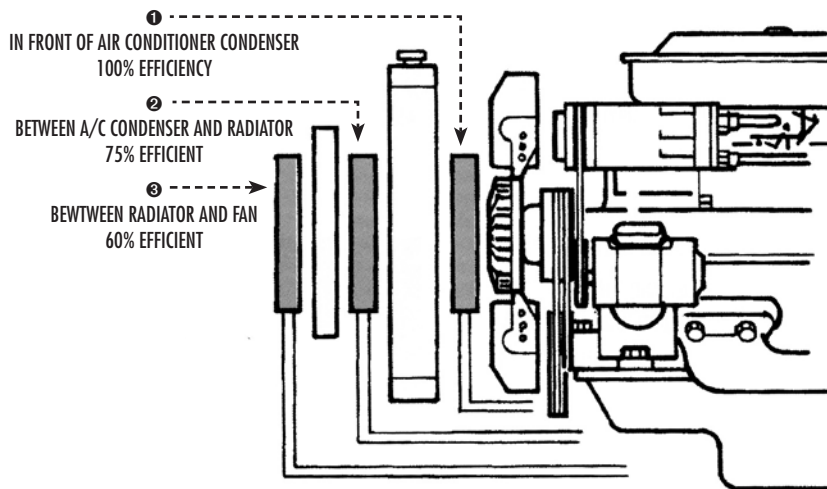

### Mounting Location

For the maximum efficiency, the cooler should be mounted where it will receive the coolest air and maximum air flow. This is usually directly in front of the radiator or air conditioning condenser. Use alternative positions 2 or 3 if sufficient room up front is unavailable. Be sure to compensate for the loss of cooling efficiency by using a cooler one or two sizes larger.

# COOLER ACCESSORIES

## Technical Guide

- 270** OIL TEMPERATURE GAUGE SENDER FITTING  
Bulkhead type fitting that installs in the transmission pan. Can be used to install a 1/8" MPT temperature sender, or used as a drain plug.
- 275** OIL TEMPERATURE GAUGE  
Monitors transmission or engine oil temperature. Features 160F – 320F range. Complete with mounting bezel, sender, sender fitting and wiring.

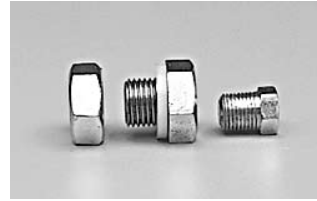

270



275

### Hose And Line Kits

- 105** TRANSMISSION OIL COOLER HOSE  
1 1/32" x 4-1/2'
- 106** TRANSMISSION OIL COOLER HOSE  
3/8" x 4-1/2'
- 112** ENGINE OIL COOLER HOSE  
1/2" x 12'
- 125** TRANSMISSION OIL COOLER HOSE  
1 1/32" x 25'
- 126** TRANSMISSION OIL COOLER HOSE  
3/8" x 25'
- 251** TRANSMISSION OIL COOLER REINSTALLATION KIT  
Contains PART #'s 105, 210, 250 and four hose clamps.
- 293** METAL LINE KIT  
For engine oil coolers. Routes oil lines past exhaust manifolds.



105, 106



251



293

### Cooler Mounting Kits

- 153** METAL MOUNTING BRACKET KIT  
For 1-1/2" thick coolers.  
PART #'s 1015, 1040, 1046, 1240
- 253** METAL MOUNTING BRACKET KIT  
For 3/4" thick coolers.  
PART #'s 401-405, 457-462, 676-679
- 209, 210** MOUNTING KIT, FOR TRANS-COOLERS AND ELECTRIC FANS  
Contains nylon rods, foam pads, and removable locking buttons. 209 is in retail clamshell packaging. 210 is in a plastic bag.



153, 253



209, 210



250



252

### Trans-Cooler Installation Fittings

- 250** QUIK-CONNECT® COUPLER  
Fits most 5/16" trans-lines with 1/2"-20 thread
- 252** FORD, 1/4", 3/8" NPT FITTINGS
- 390** GM-FORD-JEEP, 5/8"-18 INVERTED FLARE
- 391** JEEP, 5/8"-18 S.A.E. 45° FITTINGS
- 392** DODGE-JEEP, 3/8" X 3/8" HOSE SPLICERS
- 393** GM, 1/2"-20 INVERTED FLARE, FULL THREAD
- 394** FORD, 1/2"-20 INVERTED FLARE, PARTIAL THREAD
- 395** FORD, 5/8"-18 INVERTED FLARE, PARTIAL THREAD
- 396** DODGE, JEEP, 9/16"-18 37° JIC FLARE
- 397** GM, FITS SNAP-IN TRANS-LINE TYPE FITTINGS
- 398** DODGE, JEEP, 9/16"-24 45° JIC FLARE



390, 393, 394, 395



391, 396, 398



392



397

COOLERS

# COOLER ACCESSORIES

## Technical Guide

COOLERS



205



211



214



291



2106

### Thermostatic Sandwich Adapters

Designed to fit between the filter and the block, these thermostatic adapters begin directing oil to the cooler when the oil temperature reaches 160°F and releases all oil to the cooler when the temperature reaches 180°F.

**205** – Fits Ford, Chrysler and imports. 3/8" FPT ports with 3/4"-16 thread mounting nut.

**211** – Fits Chevrolet and GM with large (3-1/2") O-ring diameter. 1/2" FPT ports with 13/16"-16 thread mounting nut.

**225** – Fits AMC, Jeep, some GM with small (2-3/4") O-ring. 3/8" FPT ports with 13/16"-16 thread mounting nut.

**242** – Fits 1976 and later GM. 3/8" FPT ports with 18mm x 1.5 thread mounting nut.

**243** – Fits AMC and imports 3/8" FPT ports with 20mm x 1.5 thread mounting nut. Some O.E. filters may not seal, use FRAM #PH3950 or equivalent.

The out port is on the left with O-ring side up, facing ports. CAUTION: To avoid oil pressure loss and possible engine damage, do not use sandwich adapters to install transmission coolers as engine oil coolers.

### Remote Filter Mount Kits (Non-Thermostatic)

For use when relocation of the oil filter is necessary, these mounting kits include all hardware necessary except hoses.

**214** – Fits Chevrolet and GM with large (3-1/2") O.D. O-ring.

**291** – Universal remote filter mount, fits small (2-3/4") O.D. O-ring only. Includes 3/4"-16", 13/16"-16, 18mm x 1.5, 20mm x 1.5 adapters.

**2106** – Compatible with engine oil or transmission fluid. 3/8" FPT ports facing forward. No block adapter included.

1 REMOTE FILTER MOUNTS HAVE 3/8" FPT PORTS.

2 BLOCK OFF ADAPTERS HAVE 1/2" FPT PORTS.

3 ALL FILTER MOUNTS USE FORD TYPE FILTERS, SUCH AS FRAM PH8A OR EQUIVALENT.

4 USE #112 HOSE FOR ENGINE APPLICATIONS, #105 FOR TRANSMISSION APPLICATIONS.

### Oil Thermostat



163

**163** – Oil thermostat for use with engine oil or transmission fluid begins closing at 160°F, fully closed at 180°F, 3/8" FPT fittings.

# TRANSMISSION/ENGINE OIL COOLERS

## Application Guide

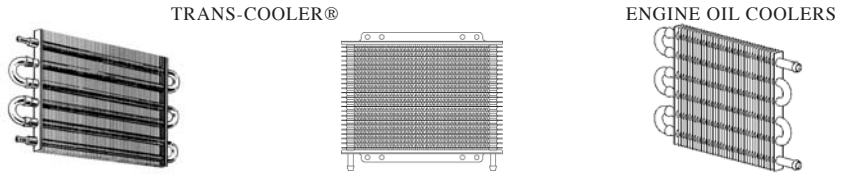

YEAR	TYPE	CID	ENGINE LITERS (VIN)	APPLICATION	ULTRA-COOL®			HIGH PERFORMANCE			RAPID-COOL®			REQUIRED TRANS FITTING KIT		TRANS COOL NOTE		REMOTE ENGINE KIT (1)		ENGINE COOLER NOTE
					LIGHT DUTY	MEDIUM DUTY	HEAVY DUTY	LIGHT DUTY	MEDIUM DUTY	HEAVY DUTY	LIGHT DUTY	MEDIUM DUTY	HEAVY DUTY	LIGHT DUTY	MEDIUM DUTY	HEAVY DUTY	LIGHT DUTY	MEDIUM DUTY	HEAVY DUTY	LIGHT DUTY
<b>ACURA CARS AND TRUCKS</b>																				
07-96	V6	215	3.5	RL, SLX, MDX	401	402	403	512	512	514	676	677	678	N/R	-	-	-	-	-	-
07-91	V6	196	3.2	CL, TL, LEGEND	401	402	403	512	512	514	676	677	678	N/R	-	-	-	-	-	-
2005	V6	196	3.2	NSX	401	402	403	512	512	514	676	677	678	N/R	-	-	-	-	-	-
2005	V6	184	3.0	NSX	401	402	403	512	512	514	676	677	678	N/R	-	-	-	-	-	-
99-97	V6	184	3.0	CL	401	402	403	512	512	514	676	677	678	N/R	-	-	-	-	-	-
90-87	V6	166	2.7	LEGEND	401	402	403	512	512	514	676	677	678	N/R	-	-	-	-	-	-
98-95	L5	154	2.5	TL, VIGOR	401	402	403	512	512	514	676	677	678	N/R	-	-	-	-	-	-
87-86	V6	154	2.5	LEGEND	401	402	403	512	512	514	676	677	678	N/R	-	-	-	-	-	-
99-98	L4	141	2.3	CL	401	402	403	512	512	514	676	677	678	N/R	-	-	-	-	-	-
2007	L4	141	2.3	RDX	401	402	403	512	512	514	676	677	678	N/R	-	-	-	-	-	-
07-05	L4	141	2.4	TSX	401	402	403	512	512	514	676	677	678	N/R	-	-	-	-	-	-
06-02	L4	123	2.0	RSX	401	402	403	512	512	514	676	677	678	N/R	-	-	-	-	-	-
01-90	L4	111	1.8	INTEGRA	401	402	403	512	512	514	676	677	678	N/R	-	-	-	-	-	-
93-92	L4	104	1.7	INTEGRA	401	402	403	512	512	514	676	677	678	N/R	-	-	-	-	-	-
01-97	L4	98	1.6	EL	401	402	403	512	512	514	676	677	678	N/R	-	-	-	-	-	-
89-86	L4	98	1.6	INTEGRA	401	402	403	512	512	514	676	677	678	N/R	-	-	-	-	-	-
<b>AMC CARS (Also See Jeep and Eagle)</b>																				
74-71	V8	401	6.6	ALL MODELS	403	404	405	512	514	516	677	678	679	N/R	459	457	1040	291	-	-
78-70	V8	360	5.9	ALL MODELS	403	404	405	512	514	516	677	678	679	N/R	459	457	1040	291	-	-
79-70	V8	304	5.0	ALL MODELS	403	404	405	512	514	516	677	678	679	N/R	459	457	1040	291	-	-
83-71	L6	258	4.2	ALL MODELS	401	402	403	512	512	514	676	677	678	N/R	459	457	1040	291	-	-
79-65	L6	232	3.8	ALL MODELS	401	402	403	512	512	514	676	677	678	N/R	459	457	1040	291	-	-
70-65	L6	199	3.3	ALL MODELS	401	402	403	512	512	514	676	677	678	N/R	459	457	1040	291	-	-
84-80	L4	151	2.5	ALL MODELS	401	402	403	512	512	514	676	677	678	N/R	459	457	457	291	(2)	-
79-77	L4	122	2.0	ALL MODELS	401	402	403	512	512	514	676	677	678	N/R	459	459	457	291	-	-
<b>BUICK</b>																				
76-70	V8	455	7.4	ALL MODELS	403	404	405	512	514	516	677	678	679	N/R	459	457	1040	291	-	-
69-63	V8	430	7.0	ALL MODELS	403	404	405	512	514	516	677	678	679	N/R	459	457	1040	291	-	-
79-77	V8	403	6.6	ALL MODELS	403	404	405	512	514	516	677	678	679	N/R	459	457	1040	291	-	-
67-60	V8	401	6.6	ALL MODELS	403	404	405	512	514	516	677	678	679	N/R	459	457	1040	291	-	-
75-69	V8	400	6.6	ALL MODELS	403	404	405	512	514	516	677	678	679	N/R	459	457	1040	291	-	-
96-94	V8	350	5.7 (P)	ROADMASTER	403	404	404	512	514	514	677	678	679	397 OR 390	459	457	1040	291	-	-
93-92	V8	350	5.7 (7)	ROADMASTER	403	404	404	512	514	514	677	678	679	397 OR 390	462	461	1046	214	-	-
85-80	V8	350	5.7 (N)	DIESEL	403	404	404	512	514	514	677	678	679	N/R	-	-	-	-	-	-
81	V8	350	5.7 (B)	ELECTRA	403	404	404	512	514	514	677	678	679	397 OR 390	459	457	1040	291	-	-
80-77	V8	350	5.7 (R)	ALL MODELS	403	404	404	512	514	514	677	678	679	N/R	459	457	1040	291	-	-
80-78	V8	350	5.7 (X)	ELECTRA, LESABRE, RIVIERA	403	404	404	512	514	514	677	678	679	N/R	459	457	1040	291	-	-
79-77	V8	350	5.7 (L)	CENTURY, REGAL, SKYLARK	403	404	404	512	514	514	677	678	679	N/R	462	461	1046	214	-	-
77-72	V8	350	5.7 (H)	ALL MODELS	403	404	404	512	514	514	677	678	679	N/R	459	457	1040	291	-	-
77-72	V8	350	5.7 (J)	ALL MODELS	403	404	404	512	514	514	677	678	679	N/R	459	457	1040	291	-	-
72	V8	350	5.7 (K)	ALL MODELS	403	404	404	512	514	514	677	678	679	N/R	459	457	1040	291	-	-
07-04	L6	256	5.3	RAINIER	403	404	404	512	514	514	677	678	679	397	-	-	-	-	-	-
90-80	V8	307	5.0 (Y)	ALL MODELS	403	404	404	512	514	514	677	678	679	N/R	459	457	1040	291	-	-
91	V8	305	5.0 (E)	ALL MODELS	403	404	404	512	514	514	677	678	679	N/R	462	461	1046	214	-	-

(1) Remote filter mount kit is optional unless otherwise noted.

(2) Check for 2" oil filter clearance, some vehicles require remote kit #291.

# TRANSMISSION/ENGINE OIL COOLERS

## Application Guide

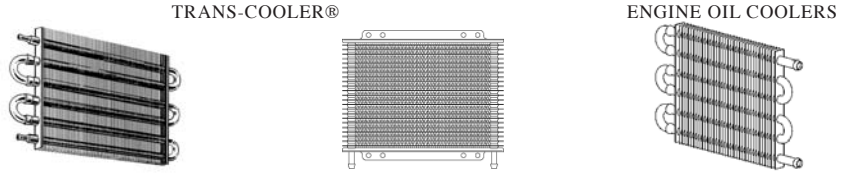

ULTRA-COOL® HIGH PERFORMANCE RAPID-COOL®

YEAR	TYPE	CID	ENGINE LITERS (VIN)	APPLICATION	ULTRA-COOL®			HIGH PERFORMANCE			RAPID-COOL®			REQUIRED FITTING KIT	TRANS COOL NOTE	REMOTE ENGINE KIT (1)			ENGINE COOLER NOTE
					LIGHT DUTY	MEDIUM DUTY	HEAVY DUTY	LIGHT DUTY	MEDIUM DUTY	HEAVY DUTY	LIGHT DUTY	MEDIUM DUTY	HEAVY DUTY			LIGHT DUTY	MEDIUM DUTY	HEAVY DUTY	
<b>BUICK (Cont'd)</b>																			
87-78	V8	305	5.0 (H)	ALL MODELS	403	404	404	512	514	514	677	678	679	N/R		462	461	1046	214
79	V8	305	5.0 (G)	ALL MODELS	403	404	404	512	514	514	677	678	679	N/R		462	461	1046	214
78-77	V8	305	5.0 (U)	ALL MODELS	403	404	404	512	514	514	677	678	679	N/R		462	461	1046	214
80-77	V8	301	4.9 (Y)	ALL MODELS	403	404	405	512	514	516	677	678	679	N/R		459	457	1040	291
80-79	V8	301	4.9 (W)	ALL MODELS	403	404	405	512	514	516	677	678	679	N/R		459	457	1040	291
67-64	V8	300	4.9	ALL MODELS	403	404	405	512	514	516	677	678	679	N/R		459	457	1040	291
07-06	V8	281	4.6	LUCERNE	403	404	405	512	514	516	677	678	679	397		-	-	-	-
82-81	V8	267	4.4 (J)	ALL MODELS	401	402	403	512	512	514	676	677	678	N/R		462	461	1046	214
81-75	V6	260	4.3 (F)	GAS, ALL MODELS	401	402	403	512	512	514	676	677	678	N/R		459	457	1040	291
85-82	V6	260	4.3 (T)	DIESEL, ALL MODELS	401	402	403	512	512	514	676	677	678	N/R		-	-	-	-
07-04	L6	256	4.2	RAINIER	403	404	404	512	514	514	677	678	679	397		-	-	-	-
84-80	V6	252	4.1 (4)	ALL MODELS	401	402	403	512	512	514	676	677	678	N/R		459	457	1040	291
75-68	L6	250	4.1 (D)	ALL MODELS	401	402	403	512	512	514	676	677	678	N/R		459	457	1040	291
07-06	V6	237	3.9	TERRAZA, CXL, CX	401	402	403	512	512	514	676	677	678	397		459	457	1040	291
05-01	V6	231	3.8	PARK AVENUE	401	402	403	512	512	514	676	677	678	397		459	457	1040	291
2005	V6	231	3.8	CENTURY	401	402	403	512	512	514	676	677	678	397		459	457	1040	291
04-00	V6	231	3.8	REGAL	401	402	403	512	512	514	676	677	678	397		459	457	1040	291
05-01	V6	231	3.8	LE SABRE	401	402	403	512	512	514	676	677	678	397		459	457	1040	291
2000	V6	231	3.8	PARK AVENUE, LE SABRE	401	402	403	512	512	514	676	677	678	397 OR 390		459	457	1040	291
99-90	V6	231	3.8	ALL MODELS	401	402	403	512	512	514	676	677	678	397 OR (14) 390		459	457	1040	291
89-75	V6	231	3.8	INCLUDING TURBO	401	402	403	512	512	514	676	677	678	397 OR 390		459	457	1040	291
07-05	V6	231	3.8	ALLURE, LACROSSE, LUCERNE	401	402	403	512	512	514	676	677	678	397		-	-	-	-
07-05	V6	217	3.6	ALLURE, LACROSSE	401	402	403	512	512	514	676	677	678	397		-	-	-	-
06-04	V6	220	3.6	RENDEZVOUS ULTRA	401	402	403	512	512	514	676	677	678	397		-	-	-	-
06-05	V6	213	3.5	TERRAZA, CXL, CX	401	402	403	512	512	514	676	677	678	397		-	-	-	-
07-06	V6	213	3.5	RENDEZVOUS, ULTRA	401	402	403	512	512	514	676	677	678	397		-	-	-	-
05-04	V6	207	3.4	RENDEZVOUS	401	402	403	512	512	514	676	677	678	397		-	-	-	-
93-89	V6	204	3.3 (N)	ALL MODELS	401	402	403	512	512	514	676	677	678	397 OR (14) 390		459	457	1040	291
79-78	V6	196	3.2	ALL MODELS	401	402	403	512	512	514	676	677	678	N/R		459	457	1040	291
03-01	V6	189	3.1	PARK AVENUE	401	402	403	512	512	514	676	677	678	397		459	457	1040	291
05-00	V6	189	3.1	CENTURY	401	402	403	512	512	514	676	677	678	397		459	457	1040	291
03-01	V6	189	3.1	LE SABRE	401	402	403	512	512	514	676	677	678	397		459	457	1040	291
2000	V6	189	3.1	PARK AVENUE, LE SABRE	401	402	403	512	512	514	676	677	678	397 OR 390		459	457	1040	291
99-89	V6	189	3.1	ALL MODELS	401	402	403	512	512	514	676	677	678	397 OR (14) 390		459	457	1040	291
88-82	V6	181	3.0	ALL MODELS	401	402	403	512	512	514	676	677	678	N/R		459	457	1040	291
89-80	V6	173	2.8	ALL MODELS	401	402	403	512	512	514	676	677	678	N/R		459	457	1040	291
92-88	L4	151	2.5	ALL MODELS	401	402	403	512	512	514	676	677	678	397 OR (14) 390		459	457	1040	291
91-85	L4	151	2.5 (U)	ALL MODELS	401	402	403	512	512	514	676	677	678	N/R (14)		-	-	-	- (11)
92-82	L4	151	2.5 (R)	ALL MODELS	401	402	403	512	512	514	676	677	678	N/R (14)		-	-	-	- (11)
83-80	L4	151	2.5 (S)	ALL MODELS	401	402	403	512	512	514	676	677	678	N/R		459	457	1040	291 (11)

(1) Remote filter mount kit is optional unless otherwise noted.  
 (14) 1991 and later vehicles with 5/8" hex on trans line fittings requires kit #390.

(11) No application for engines with internal oil filters.

# TRANSMISSION/ENGINE OIL COOLERS

## Application Guide

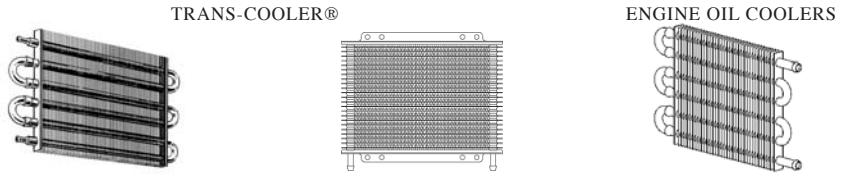

YEAR	TYPE	CID	ENGINE LITERS (VIN)	APPLICATION	ULTRA-COOL®			HIGH PERFORMANCE			RAPID-COOL®			REQUIRED FITTING KIT	TRANS COOL. NOTE	REMOTE ENGINE KIT (1)			COOLER NOTE
					LIGHT DUTY	MEDIUM DUTY	HEAVY DUTY	LIGHT DUTY	MEDIUM DUTY	HEAVY DUTY	LIGHT DUTY	MEDIUM DUTY	HEAVY DUTY			LIGHT DUTY	MEDIUM DUTY	HEAVY DUTY	
<b>BUICK (Cont'd)</b>																			
98-96	L4	146	2.4	ALL MODELS	401	402	403	512	512	514	676	677	678	397 OR 390 (14)	459	457	1040	291	
95-88	L4	138	2.3	ALL MODELS	401	402	403	512	512	514	676	677	678	397 OR 390 (14)	459	457	1040	291	
96-93	L4	134	2.2	ALL MODELS	401	402	403	512	512	514	676	677	678	397 OR 390 (14)	459	457	1040	291	
89-82	L4	122	2.0	ALL MODELS	401	402	403	512	512	514	676	677	678	N/R	459	457	1040	291	
86-82	L4	112	1.8	ALL MODELS	401	402	403	512	512	514	676	677	678	N/R	459	457	1040	291	
<b>CADILLAC</b>																			
76-70	V8	500	8.2	ALL MODELS	403	404	405	512	514	516	677	678	679	N/R	459	457	1040	291	
74-68	V8	472	7.7	ALL MODELS	403	404	405	512	514	516	677	678	679	N/R	459	457	1040	291	
67-64	V8	429	7.0	ALL MODELS	403	404	405	512	514	516	677	678	679	N/R	459	457	1040	291	
79-77	V8	425	7.0 (S)	ALL MODELS	403	404	405	512	514	516	677	678	679	N/R	459	457	1040	291	
79-77	V8	425	7.0 (T)	ALL MODELS	403	404	405	512	514	516	677	678	679	N/R	459	457	1040	291	
2007	V8	364	6.2	ESCALADE, EXT, ESV	403	404	405	512	514	516	677	678	679	397 OR 390 (14)	-	-	-	-	
07-02	V8	364	6.0	ESCALADE, EXT, ESV	403	404	405	512	514	516	677	678	679	397 OR 390 (14)	-	-	-	-	
84-80	V8	364	6.0 (9)	ALL MODELS	403	404	405	512	514	516	677	678	679	N/R	-	-	-	-	
82-80	V8	364	6.0 (6)	ALL MODELS	403	404	405	512	514	516	677	678	679	N/R	459	457	1040	291	
00-99	V8	350	5.7 (R)	ESCALADE TWO WHEEL DRIVE	403	404	405	512	514	516	677	678	679	397 OR 390	462	461	1046	214	
00-99	V8	350	5.7 (R)	ESCALADE FOUR WHEEL DRIVE	403	404	405	512	514	516	677	678	679	397 OR 390	459	457	1040	291	
96-94	V8	350	5.7 (P)	FLEETWOOD & INC. BROUGHAM	403	404	405	512	514	516	677	678	679	397 OR 390	459	457	1040	291	
93-90	V8	350	5.7 (7)	FLEETWOOD & COMMERCIAL CHASSIS	403	404	405	512	514	516	677	678	679	397 OR 390	462	461	1046	214	
85-75	V8	350	5.7 (N)	DIESEL, ALL MODELS	403	404	405	512	514	516	677	678	679	N/R	-	-	-	-	
80	V8	350	5.7 (8)	ELDORADO & SEVILLE	403	404	405	512	514	516	677	678	679	N/R	459	457	1040	291	
79-76	V8	350	5.7 (R)	ELDORADO & SEVILLE	403	404	405	512	514	516	677	678	679	N/R	459	457	1040	291	
79	V8	350	5.7 (B)	ELDORADO & SEVILLE	403	404	405	512	514	516	677	678	679	N/R	459	457	1040	291	
05-02	V8	323	5.3	ESCALADE	403	404	405	512	514	516	677	678	679	397 OR 390	-	-	-	-	
90-87	V8	307	5.0 (9)	BROUGHAM	403	404	405	512	514	516	677	678	679	N/R	459	457	1040	291	
90-86	V8	307	5.0 (Y)	BROUGHAM	403	404	405	512	514	516	677	678	679	N/R	459	457	1040	291	
92-91	V8	305	5.0 (E)	BROUGHAM & COMMERCIAL CHASSIS	403	404	405	512	514	516	677	678	679	N/R	462	461	1046	214	
95-91	V8	300	4.9 (B)	ALL MODELS	401	402	403	512	512	514	676	677	678	397 OR 390	-	-	-	-	
01-93	V8	281	4.6 (Y)	ALL MODELS	401	402	403	512	512	514	676	677	678	397 OR 390	-	-	-	-	
05-01	V8	281	4.6 (9)	SEVILLE & DEVILLE	401	402	403	512	512	514	676	677	678	397	-	-	-	-	
00-93	V8	281	4.6 (9)	ALL MODELS	401	402	403	512	512	514	676	677	678	397 OR 390	-	-	-	-	
92-88	V8	273	4.5 (3)	ALL MODELS	401	402	403	512	512	514	676	677	678	397 OR 390 (14)	-	-	-	-	
85	V6	260	4.3 (T)	DEVILLE DIESEL	401	402	403	512	514	516	677	678	679	N/R	-	-	-	-	

(1) Remote filter mount kit is optional unless otherwise noted.

(14) 1991 and later vehicles with 5/8" hex on trans line fittings requires kit #390.

# TRANSMISSION/ENGINE OIL COOLERS

## Application Guide

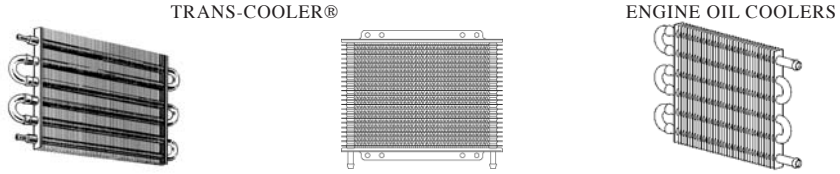

ULTRA-COOL® HIGH PERFORMANCE RAPID-COOL®

ENGINE OIL COOLERS

YEAR	TYPE	CID	ENGINE LITERS (VIN)	APPLICATION	ULTRA-COOL®			HIGH PERFORMANCE			RAPID-COOL®			REQUIRED TRANS FITTING KIT		REMOTE ENGINE KIT (1)		ENGINE COOLER NOTE
					LIGHT DUTY	MEDIUM DUTY	HEAVY DUTY	LIGHT DUTY	MEDIUM DUTY	HEAVY DUTY	LIGHT DUTY	MEDIUM DUTY	HEAVY DUTY	NOTE	NOTE			
<b>CADILLAC (Cont'd)</b>																		
88-82	V8	250	4.1 (8)	ALL MODELS	401	402	403	512	512	514	676	677	678	397 OR 390	-	-	-	-
82-80	V8	252	4.1 (4)	ALL MODELS	401	402	403	512	512	514	676	677	678	397 OR 390	-	-	-	-
01-97	V6	181	3.0 (R)	CATERA	401	402	403	512	512	514	676	677	678	397 OR 390	-	-	-	-
88-85	V6	173	2.8 (W)	CIMMARON	401	402	403	512	512	514	676	677	678	N/R	459	459	457	291
86-83	L4	122	2.0 (P)	CIMMARON	401	402	403	512	512	514	676	677	678	N/R	459	459	457	291
82	L4	112	1.8 (G)	CIMMARON	401	402	403	512	512	514	676	677	678	N/R	459	459	457	291
<b>CHEVROLET CARS</b>																		
76-69	V8	454	7.4	ALL MODELS	403	404	405	512	514	516	677	678	679	N/R	462	461	1046	214
69-66	V8	427	7.0	ALL MODELS	403	404	405	512	514	516	677	678	679	N/R	462	461	1046	214 (7)
65-61	V8	409	6.7	ALL MODELS	403	404	405	512	514	516	677	678	679	N/R	-	-	-	- (7)
72-70	V8	402	6.6	ALL MODELS	403	404	405	512	514	516	677	678	679	N/R	462	461	1046	214
76-70	V8	400	6.6	ALL MODELS	403	404	405	512	514	516	677	678	679	N/R	462	461	1046	214
70-69	V8	396	6.5	ALL MODELS	403	404	405	512	514	516	677	678	679	N/R	462	461	1046	214 (7)
68	V8	396	6.5	ALL MODELS	403	404	405	512	514	516	677	678	679	N/R	-	-	-	- (7)
02-98	V8	350	5.7 (G)	CAMARO	403	404	405	512	514	516	677	678	679	390	462	461	1046	214
04-97	V8	350	5.7	CORVETTE	403	404	405	512	514	516	677	678	679	390	-	-	-	-
96-94	V8	350	5.7 (P)	IMPALA SS	403	404	405	512	514	516	677	678	679	390	459	457	1040	291
96-92	V8	350	5.7 (P)	CORVETTE	403	404	405	512	514	516	677	678	679	390	-	-	-	-
95-90	V8	350	5.7 (J)	CORVETTE	403	404	405	512	514	516	677	678	679	390	-	-	-	-
91-79	V8	350	5.7 (8)	CORVETTE	403	404	405	512	514	516	677	678	679	N/R	462	461	1046	214
93-89	V8	350	5.7 (7)	CAPRICE	403	404	405	512	514	516	677	678	679	390 (14)	462	461	1046	214
92-87	V8	350	5.7 (8)	CAMARO	403	404	405	512	514	516	677	678	679	390 (14)	462	461	1046	214
88-80	V8	350	5.7 (6)	CAPRICE, IMPALA, CORVETTE	403	404	405	512	514	516	677	678	679	N/R	462	461	1046	214
85-80	V8	350	5.7 (N)	ALL DIESEL	403	404	405	512	514	516	677	678	679	N/R	-	-	-	-
82-74	V8	350	5.7 (K)	ALL MODELS	403	404	405	512	514	516	677	678	679	N/R	462	461	1046	214
79-78	V8	350	5.7 (4)	MALIBU, CORVETTE	403	404	405	512	514	516	677	678	679	N/R	462	461	1046	214
78-72	V8	350	5.7 (H)	ALL MODELS	403	404	405	512	514	516	677	678	679	N/R	462	461	1046	214
77-76	V8	350	5.7 (X)	CORVETTE	403	404	405	512	514	516	677	678	679	N/R	462	461	1046	214
76	V8	350	5.7 (V)	ALL MODELS	403	404	405	512	514	516	677	678	679	N/R	462	461	1046	214
75-74	V8	350	5.7 (T)	CAMARO, CORVETTE	403	404	405	512	514	516	677	678	679	N/R	462	461	1046	214
75-72	V8	350	5.7 (J)	ALL MODELS	403	404	405	512	514	516	677	678	679	N/R	462	461	1046	214
74-72	V8	350	5.7 (K)	ALL MODELS	403	404	405	512	514	516	677	678	679	N/R	462	461	1046	214
71-67	V8	350	5.7	ALL MODELS	403	404	405	512	514	516	677	678	679	N/R	462	461	1046	214
61-60	V8	348	5.7	ALL MODELS	403	404	405	512	514	516	677	678	679	N/R	-	-	-	- (7)
69-62	V8	327	5.4	ALL MODELS	403	404	405	512	514	516	677	678	679	N/R	-	-	-	- (7)
90-86	V8	307	5.0 (Y)	CAPRICE	403	404	405	512	514	516	677	678	679	390 (14)	459	457	1040	291
73-68	V8	307	5.0	ALL MODELS	403	404	405	512	514	516	677	678	679	N/R	462	461	1046	214
93-90	V8	305	5.0 (E)	ALL MODELS	403	404	405	512	514	516	677	678	679	390 (14)	462	461	1046	214
89-76	V8	305	5.0	ALL MODELS	403	404	405	512	514	516	677	678	679	N/R	462	461	1046	214
68-67	V8	302	5.0	CAMARO	403	404	405	512	514	516	677	678	679	N/R	462	461	1046	214
67-60	V8	283	4.6	ALL MODELS	403	404	405	512	514	516	677	678	679	N/R	-	-	-	- (7)
82-79	V8	267	4.4	ALL MODELS	403	404	405	512	514	516	677	678	679	N/R	462	461	1046	214
96-94	V8	265	4.3 (W)	CAPRICE	403	404	405	512	514	516	677	678	679	390 (14)	459	457	1040	291
93-85	V6	262	4.3 (Z)	ALL MODELS	403	404	405	512	514	516	677	678	679	390 (14)	459	457	1040	291

(1) Remote filter mount kit is optional unless otherwise noted.  
 (14) 1991 and later vehicles with 5/8" hex on trans line fittings requires kit #390.

(7) No engine oil cooler applications on engines with canister style oil filters.

# TRANSMISSION/ENGINE OIL COOLERS

## Application Guide

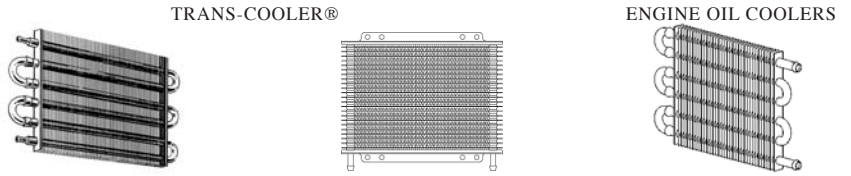

YEAR	TYPE	CID	ENGINE LITERS (VIN)	APPLICATION	ULTRA-COOL®			HIGH PERFORMANCE			RAPID-COOL®			REQUIRED TRANS FITTING KIT		REMOTE ENGINE KIT (1)			
					LIGHT DUTY	MEDIUM DUTY	HEAVY DUTY	LIGHT DUTY	MEDIUM DUTY	HEAVY DUTY	LIGHT DUTY	MEDIUM DUTY	HEAVY DUTY	COOLR NOTE	LIGHT DUTY	MEDIUM DUTY	HEAVY DUTY	COOLER NOTE	
<b>CHEVROLET CARS (Cont'd)</b>																			
76-75	V6	262	4.3 (G)	MONZA, VEGA, NOVA	403	404	405	512	514	516	677	678	679	N/R		459	457	1040	291
85-82	V6	260	4.3 (T)	CELEBRITY DIESEL	403	404	405	512	514	516	677	678	679	N/R		-	-	-	-
79-65	L6	250	4.1	ALL MODELS	401	402	404	512	512	514	676	677	678	N/R		459	457	1040	291
62-61	L6	235	3.9	ALL MODELS	401	402	404	512	512	514	676	677	678	N/R		-	-	-	- (7)
05-00	V6	231	3.8	LUMINA, MONTE CARLO, IMPALA	401	402	403	512	512	514	676	677	678	397		459	457	1040	291
99-00	V6	231	3.8	ALL MODELS	401	402	403	512	512	514	676	677	678	390		459	457	1040	291
99-90	V6	231	3.8	ALL MODELS	401	402	403	512	512	514	676	677	678	390		459	457	1040	291
01-90	V6	231	3.8	ALL MODELS	401	402	403	512	512	514	676	677	678	390		459	457	1040	291
89-78	V6	231	3.8	ALL MODELS	401	402	403	512	512	514	676	677	678	N/R		459	457	1040	291
70-63	L6	230	3.8	ALL MODELS	401	402	403	512	512	514	676	677	678	390		459	457	1040	291
05-01	V6	207	3.4	LUMINA, MONTE CARLO, IMPALA	401	402	403	512	512	514	676	677	678	397		459	457	1040	291
01-00	V6	207	3.4	VENTURE APV	401	402	403	512	512	514	676	677	678	397		459	457	1040	291
99-91	V6	207	3.4	ALL MODELS	401	402	403	512	512	514	676	677	678	390		459	457	1040	291
79-78	V6	200	3.3	ALL MODELS	401	402	403	512	512	514	676	677	678	N/R		459	457	1040	291
79-78	V6	196	3.2	ALL MODELS	401	402	403	512	512	514	676	677	678	N/R		459	457	1040	291
66-62	L6	194	3.2	ALL MODELS	401	402	403	512	512	514	676	677	678	390		462	461	1046	214
03-90	V6	189	3.1	ALL MODELS	401	402	403	512	512	514	676	677	678	390		459	457	1040	291
89-80	V6	173	2.8	ALL MODELS	401	402	403	512	512	514	676	677	678	N/R		459	457	1040	291
86-82	L4	151	2.5 (2)	CAMARO	401	402	403	512	512	514	676	677	678	N/R		459	457	1040	291
83-80	L4	151	2.5 (5)	CELEBRITY, CITATION	401	402	403	512	512	514	676	677	678	N/R		459	457	1040	291
79-78	L4	151	2.5 (1)	MONZA	401	402	403	512	512	514	676	677	678	N/R		462	461	1046	214
79	L4	151	2.5 (9)	MONZA	401	402	403	512	512	514	676	677	678	N/R		459	457	1040	291
83-82	L4	151	2.5 (F)	CAMARO	401	402	403	512	512	514	676	677	678	N/R		459	457	1040	291
90-82	L4	151	2.5 (R)	CELEBRITY	401	402	403	512	512	514	676	677	678	N/R		-	-	-	-
85-82	L4	151	2.5 (R)	CITATION	401	402	403	512	512	514	676	677	678	N/R		-	-	-	-
92-90	L4	151	2.5 (R)	LUMINA	401	402	403	512	512	514	676	677	678	N/R		-	-	-	-
80-78	L4	151	2.5 (V)	MONZA	401	402	403	512	512	514	676	677	678	N/R		462	461	1046	214
70-62	L4	151	2.5 (V)	ALL MODELS	401	402	403	512	512	514	676	677	678	N/R		462	461	1046	214
02-96	L4	146	2.4	ALL MODELS	401	402	403	512	512	514	676	677	678	390		459	457	1040	291
94-90	L4	140	2.3	ALL MODELS	401	402	403	512	512	514	676	677	678	390		459	457	1040	291
76-71	L4	140	2.3	ALL MODELS	401	402	403	512	512	514	676	677	678	N/R		462	461	1046	214
04-90	L4	134	2.2	ALL MODELS	401	402	403	512	512	514	676	677	678	390		462	461	1046	214
89-83	L4	122	2.0	ALL MODELS	401	402	403	512	512	514	676	677	678	N/R		459	457	1040	291
01-98	L4	112	1.8	ALL MODELS	401	402	403	512	512	514	676	677	678	N/R		-	-	-	-
<b>CHEVROLET/GMC TRUCKS</b>																			
07-01	V8	496	8.1	TRUCKS	404	405	1015	514	516	516	677	678	679	390		462	461	1046	214
00-96	V8	454	7.4	TRUCKS, SUBURBAN, BLAZER, JIMMY	404	405	1015	514	516	516	677	678	679	390		462	461	1046	214
99-96	V8	454	7.4	MOTORHOME, P-30 CHASSIS	404	405	1015	514	516	516	678	678	679	390		-	-	-	-
95-73	V8	454	7.4	TRUCKS, SUBURBAN, BLAZER, JIMMY	404	405	1015	514	516	516	677	678	679	N/R		462	461	1046	214
95-80	V8	454	7.4	MOTORHOME, P-30 CHASSIS	404	405	1015	514	516	516	678	678	679	N/R		-	-	-	-
80-73	V8	454	7.4	MOTORHOME, P-30 CHASSIS	404	405	1015	514	516	516	677	678	679	N/R		462	461	1046	214

(1) Remote filter mount kit is optional unless otherwise noted.

(7) No engine oil cooler applications on engines with canister style oil filters.

# TRANSMISSION/ENGINE OIL COOLERS

## Application Guide

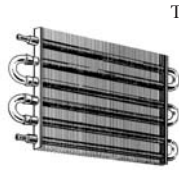

TRANS-COOLER®

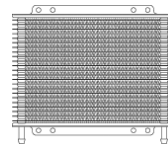

RAPID-COOL®

ENGINE OIL COOLERS

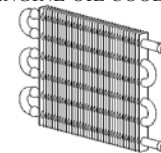

ULTRA-COOL®

HIGH PERFORMANCE

RAPID-COOL®

YEAR	TYPE	CID	ENGINE LITERS (VIN)	APPLICATION	ULTRA-COOL®			HIGH PERFORMANCE			RAPID-COOL®			REQUIRED FITTING KIT	TRANS COOL. NOTE	LIGHT DUTY	MEDIUM DUTY	HEAVY DUTY	REMOTE KIT (1)	ENGINE COOLER NOTE
					LIGHT DUTY	MEDIUM DUTY	HEAVY DUTY	LIGHT DUTY	MEDIUM DUTY	HEAVY DUTY	LIGHT DUTY	MEDIUM DUTY	HEAVY DUTY							
<b>CHEVROLET/GMC TRUCKS (Cont'd)</b>																				
65-62	V8	409	6.7	ALL TRUCKS	404	405	1015	514	516	516	677	678	679	N/R		-	-	-	-	(7)
07-01	V8	400	6.6 (1)	TURBO DIESEL SILVERADO, SIERRA	-	-	-	-	-	-	-	-	-	-	-	-	-	-	-	
80-70	V8	400	6.6	TRUCK, SUBURBAN, BLAZER, JIMMY	404	405	1015	514	516	516	677	678	679	N/R		462	461	1046	214	
69-68	V8	396	6.5	TRUCKS AND SUBURBANS	404	405	1015	514	516	516	677	678	679	N/R		-	-	-	-	
02-96	V8	395	6.5	DIESEL, ALL TRUCKS	404	405	1015	514	516	516	677	678	679	390		-	-	-	-	
95-92	V8	395	6.5	DIESEL, ALL TRUCKS	404	405	1015	514	516	516	677	678	679	N/R		-	-	-	-	
93-82	V8	379	6.2	DIESEL, ALL TRUCKS	404	405	1015	514	516	516	677	678	679	N/R		-	-	-	-	
07-04	V8	364	6.0	ALL TRUCKS, & SUBURBANS, SSR	404	405	1015	514	516	516	677	678	679	397		-	-	-	-	
07-06	V8	364	6.0	TRAILBLAZER SS	404	405	1015	514	516	516	677	678	679	397		-	-	-	-	
03-99	V8	364	6.0	ALL TRUCKS, & SUBURBANS	404	405	1015	514	516	516	677	678	679	390		-	-	-	-	
02-96	V8	350	5.7	FOUR WHEEL DRIVE TRUCKS	403	404	405	512	514	516	677	678	679	390		459	457	1040	291	
02-96	V8	350	5.7	TWO WHEEL DRIVE TRUCKS	403	404	405	512	514	516	677	678	679	390		462	461	1046	214	
95-69	V8	350	5.7	TWO WHEEL DRIVE TRUCKS	403	404	405	512	514	516	677	678	679	N/R		462	461	1046	214	
95-88	V8	350	5.7	FOUR WHEEL DRIVE TRUCKS	403	404	405	512	514	516	677	678	679	N/R		459	457	1040	291	
87-69	V8	350	5.7	FOUR WHEEL DRIVE TRUCKS	403	404	405	512	514	516	677	678	679	N/R		462	461	1046	214	
81-78	V8	350	5.7	DIESEL	403	404	405	512	514	516	677	678	679	N/R		-	-	-	214	
06-04	V8	325	5.3	SSR	403	404	405	512	514	516	677	678	679	397		-	-	-	-	
07-02	V8	323	5.3	TRAILBLAZER & ENVOY	403	404	405	512	514	516	677	678	679	397		-	-	-	-	
07-04	V8	323	5.3	ALL EXCEPT, TRAILBLAZER & ENVOY	403	404	405	512	514	516	677	678	679	397		-	-	-	-	
03-99	V8	323	5.3	ALL EXCEPT, TRAILBLAZER & ENVOY	403	404	405	512	514	516	677	678	679	390		-	-	-	-	
73-68	V8	307	5.0	ALL TRUCKS	403	404	405	512	514	516	677	678	679	N/R		462	461	1046	214	
98-96	V8	305	5.0	FOUR WHEEL DRIVE TRUCKS	403	404	405	512	514	516	677	678	679	390		459	457	1040	291	
95-88	V8	305	5.0	FOUR WHEEL DRIVE TRUCKS	403	404	405	512	514	516	677	678	679	N/R		459	457	1040	291	
98-96	V8	305	5.0	TWO WHEEL DRIVE TRUCKS	403	404	405	512	514	516	677	678	679	390		462	461	1046	214	
95-76	V8	305	5.0	TWO WHEEL DRIVE TRUCKS	403	404	405	512	514	516	677	678	679	N/R		462	461	1046	214	
87-76	V8	305	5.0	FOUR WHEEL DRIVE TRUCKS	403	404	405	512	514	516	677	678	679	N/R		462	461	1046	214	
07-04	V8	294	4.8	SILVERADO, TAHOE, SIERRA	401	402	403	512	512	514	676	677	678	397		-	-	-	-	
03-99	V8	294	4.8	SILVERADO, TAHOE, SIERRA	401	402	403	512	512	514	676	677	678	390		-	-	-	-	
88-63	L6	292	4.8	ALL TRUCKS	401	402	403	512	514	516	677	678	679	N/R		462	461	1046	214	
07-96	V6	262	4.3	ALL FULL SIZE TRUCKS	401	402	403	512	512	514	676	677	678	390		459	457	1040	291	
95-85	V6	262	4.3	ALL FULL SIZE TRUCKS	401	402	403	512	512	514	676	677	678	N/R		459	457	1040	291	
05-03	V6	262	4.3	BLAZER	403	404	405	512	514	516	677	678	679	397		-	-	-	-	
04-03	V6	262	4.3	ALL S10/S15 MID SIZE TRUCKS, SONOMA	401	402	403	512	512	514	676	677	678	390		459	457	1010	291	
02-96	V6	262	4.3	ALL S10/S15 MID SIZE TRUCKS	401	402	403	512	512	514	676	677	678	390		459	457	1040	291	
95-88	V6	262	4.3	ALL S10/S15 MID SIZE TRUCKS	401	402	403	512	512	514	676	677	678	N/R		459	457	1040	291	

(1) Remote filter mount kit is optional unless otherwise noted.

(7) No engine oil cooler applications on engines with canister style oil filters.

# TRANSMISSION/ENGINE OIL COOLERS

## Application Guide

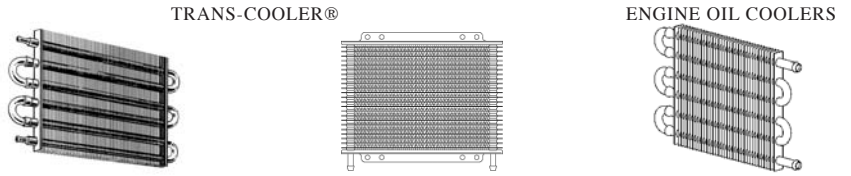

YEAR	TYPE	CID	ENGINE LITERS (VIN)	APPLICATION	ULTRA-COOL®			HIGH PERFORMANCE			RAPID-COOL®			REQUIRED TRANS FITTING KIT		TRANS COOL NOTE			REMOTE ENGINE KIT (1)		ENGINE COOLER NOTE
					LIGHT DUTY	MEDIUM DUTY	HEAVY DUTY	LIGHT DUTY	MEDIUM DUTY	HEAVY DUTY	LIGHT DUTY	MEDIUM DUTY	HEAVY DUTY	LIGHT DUTY	MEDIUM DUTY	HEAVY DUTY	LIGHT DUTY	MEDIUM DUTY	HEAVY DUTY		
<b>CHEVROLET/GMC TRUCKS (Cont'd)</b>																					
07-02	L6	258	4.2	TRAILBLAZER, ENVOY	403	404	405	512	514	516	677	678	679	397	-	-	-	-	-	-	-
84-66	L6	250	4.1	ALL TRUCKS	403	402	403	512	514	516	677	678	679	N/R	462	461	1046	214	-	-	
69-63	L6	230	3.8	ALL TRUCKS	401	402	403	512	512	514	676	677	678	N/R	459	457	1040	291	-	-	
2007	L5	227	3.7	CANYON & COLORADO	403	402	403	512	514	516	677	678	679	397	-	-	-	-	-	-	
06-04	L5	211	3.5	CANYON & COLORADO	403	402	403	512	514	516	677	678	679	397	-	-	-	-	-	-	
07-05	V6	207	3.4	EQUINOX, LT, LS	403	402	403	512	514	516	677	678	679	397	-	-	-	-	-	-	
2007	L4	178	2.9	CANYON & COLORADO	403	402	403	512	514	516	677	678	679	397	-	-	-	-	-	-	
06-04	L4	169	2.8	CANYON & COLORADO	403	402	403	512	514	516	677	678	679	397	-	-	-	-	-	-	
93-82	V6	171	2.8	ALL S10/S15 MID SIZE TRUCKS	401	402	403	512	512	514	676	677	678	N/R	459	459	457	291	(2)	-	
04-01	V6	150	2.5	TRACKER	401	402	403	512	512	514	676	677	678	N/R	459	459	457	291	(2)	-	
93-85	L4	150	2.5	ALL S10/S15 MID SIZE TRUCKS	401	402	403	512	512	514	676	677	678	N/R	459	459	457	291	(2)	-	
03-98	L4	135	2.2	ALL S10/S15 MID SIZE TRUCKS	401	402	403	512	512	514	676	677	678	390	459	459	457	291	-	-	
97-94	L4	135	2.2	ALL S10/S15 MID SIZE TRUCKS	401	402	403	512	512	514	676	677	678	N/R	459	459	457	291	-	-	
82-81	L4	135	2.2	LUV DIESEL	401	402	403	512	512	514	676	677	678	N/R	-	-	-	-	-	-	
2003	L4	122	2.0	TRACKER	401	402	403	512	512	514	676	677	678	N/R	-	-	-	-	-	-	
84-83	L4	122	2.0	ALL S10/S15 MID SIZE TRUCKS	401	402	403	512	512	514	676	677	678	N/R	459	459	457	291	-	-	
85-82	L4	118	1.9	ALL S10/S15 MID SIZE TRUCKS	401	402	403	512	512	514	676	677	678	N/R	459	459	457	291	-	-	
82-72	L4	110	1.8	LUV PICK-UP	401	402	403	512	512	514	676	677	678	N/R	459	457	1040	291	-	-	
<b>CHEVROLET &amp; GMC VANS (Including P30 Chassis Vans)</b>																					
02-01	V8	496	8.1	EXPRESS/ SAVANA VANS	404	405	405	514	516	516	677	678	679	390	-	-	-	-	-	-	
00-96	V8	454	7.4	VANS	404	405	1015	514	516	516	677	678	679	390	462	461	1046	214	-	-	
95-70	V8	454	7.4	VAN	404	405	1015	514	516	516	677	678	679	N/R	462	461	1046	214	-	-	
99-96	V8	454	7.4	MOTORHOME, P-30 CHASSIS	404	405	1015	514	516	516	678	678	679	390	-	-	-	-	-	-	
95-80	V8	454	7.4	MOTORHOME, P-30 CHASSIS	404	405	1015	514	516	516	678	678	679	N/R	-	-	-	-	-	-	
80-70	V8	454	7.4	MOTORHOME, P-30 CHASSIS	404	405	1015	514	516	516	677	678	679	N/R	462	461	1046	214	-	-	
07-06	V8	400	6.6	EXPRESS & SAVANA VANS	-	-	-	-	-	-	-	-	-	-	-	-	-	-	-	-	
80-72	V8	400	6.6	VANS	404	405	1015	514	516	516	677	678	679	N/R	462	461	1046	214	-	-	
02-96	V8	395	6.5	DIESEL, VANS INC. EXPRESS & SAVANA	404	405	1015	514	516	516	677	678	679	390	-	-	-	-	-	-	
95-94	V8	395	6.5	DIESEL, ALL VANS INCLUDING P3500	404	405	1015	514	516	516	677	678	679	N/R	-	-	-	-	-	-	
93-82	V8	379	6.2	ALL VANS	404	405	1015	514	516	516	677	678	679	N/R	-	-	-	-	-	-	
07-03	V8	368	6.0	EXPRESS & SAVANA VANS	403	404	405	512	514	516	677	678	679	390	-	-	-	-	-	-	
02-96	V8	350	5.7	VANS, INC EXPRESS & SAVANA VANS	403	404	405	512	514	516	677	678	679	390	462	461	1046	214	-	-	
95-70	V8	350	5.7	VANS	403	404	405	512	514	516	677	678	679	N/R	462	461	1046	214	-	-	
80-70	V8	350	5.7	CLASS C MOTORHOME	403	404	405	512	514	516	677	678	679	N/R	462	461	1046	214	-	-	
67	V8	327	5.4	VANS	403	404	405	512	514	516	677	678	679	N/R	-	-	-	-	-	-	
07-03	V8	323	5.3	EXPRESS & SAVANA VANS	403	404	405	512	514	516	677	678	679	390	-	-	-	-	-	-	
73-68	V8	307	5.0	VANS	403	404	405	512	514	516	677	678	679	N/R	-	-	-	-	-	-	

(1) Remote filter mount kit is optional unless otherwise noted.

(2) Check for 2" oil filter clearance, some vehicles require remote kit #291.

# TRANSMISSION/ENGINE OIL COOLERS

## Application Guide

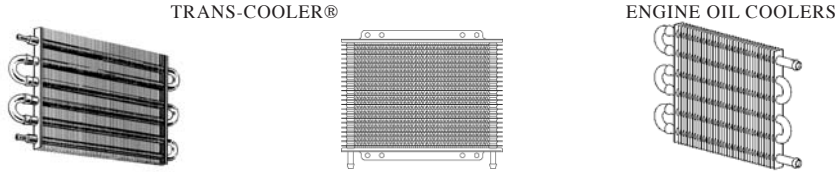

ULTRA-COOL® HIGH PERFORMANCE RAPID-COOL®

ENGINE OIL COOLERS

YEAR	TYPE	CID	ENGINE LITERS (VIN)	APPLICATION	ULTRA-COOL®			HIGH PERFORMANCE			RAPID-COOL®			REQUIRED TRANS FITTING KIT		REMOTE ENGINE KIT (1)			ENGINE COOLER NOTE
					LIGHT DUTY	MEDIUM DUTY	HEAVY DUTY	LIGHT DUTY	MEDIUM DUTY	HEAVY DUTY	LIGHT DUTY	MEDIUM DUTY	HEAVY DUTY	COOL	NOTE	LIGHT DUTY	MEDIUM DUTY	HEAVY DUTY	
<b>CHEVROLET &amp; GMC VANS (Including P30 Chassis Vans) (Cont'd)</b>																			
02-96	V8	305	5.0	EXPRESS & SAVANA VANS	403	404	405	512	514	516	677	678	679	390	462	461	1046	214	
95-77	V8	305	5.0	VANS	403	404	405	512	514	516	677	678	679	N/R	462	461	1046	214	
07-03	V8	295	4.8	EXPRESS & SAVANA VANS	403	404	405	512	514	516	677	678	679	390	-	-	-	-	
89-66	L6	292	4.8	VANS	403	404	405	512	514	516	677	678	679	N/R	462	461	1046	214	
05-96	V6	262	4.3	ASTRO & SAFARI VANS	401	402	403	512	512	514	676	677	678	390	459	457	1040	291	
95-91	V6	262	4.3	ASTRO & SAFARI VANS	401	402	403	512	512	514	676	677	678	393	459	457	1040	291	
90-85	V6	262	4.3	ASTRO & SAFARI VANS	401	402	403	512	512	514	676	677	678	393	459	457	1040	291	
07-96	V6	262	4.3	EXPRESS SAVANA & G10-30 VANS	401	402	403	512	512	514	676	677	678	390	459	457	1040	291	
95-85	V6	262	4.3	G10-30 VANS	401	402	403	512	512	514	676	677	678	390	459	457	1040	291	
84-66	L6	250	4.1	VANS	401	402	403	512	514	516	677	678	679	N/R	462	461	1046	214	
07-06	V6	237	3.9	UPLANDER	401	402	403	512	512	514	676	677	678	397	-	-	-	-	
69-63	L6	230	3.8	VANS	401	402	403	512	512	514	676	677	678	N/R	459	457	1040	291	
06-05	V6	213	3.5	UPLANDER EQUINOX, LT, LS	401	402	403	512	512	514	676	677	678	397	-	-	-	-	
05-97	V6	207	3.4	VENTURE, PLUS, LT,LS	401	402	403	512	512	514	676	677	678	397	-	-	-	-	
90-85	L4	151	2.5	ASTRO/ SAFARI VANS	401	402	403	512	512	514	676	677	678	N/R	459	457	1040	291	
<b>CHRYSLER CARS, MINI VANS AND SUVS</b>																			
78-66	V8	440	7.2	ALL MODELS	403	404	405	512	514	516	677	678	679	N/R	459	457	1040	291	
63	V8	426	7.0	ALL MODELS	403	404	405	512	514	516	677	678	679	N/R	459	457	1040	291	
65-60	V8	413	6.8	ALL MODELS	403	404	405	512	514	516	677	678	679	N/R	459	457	1040	291	
78-72	V8	400	6.6	ALL MODELS	403	404	405	512	514	516	677	678	679	N/R	459	457	1040	291	
71-60	V8	383	6.3	ALL MODELS	403	404	405	512	514	516	677	678	679	N/R	459	457	1040	291	
64-61	V8	361	5.9	ALL MODELS	403	404	405	512	514	516	677	678	679	N/R	459	457	1040	291	
80-71	V8	360	5.9	ALL MODELS	403	404	405	512	514	516	677	678	679	N/R	459	457	1040	291	
89-75	V8	318	5.2	ALL MODELS	401	402	403	512	512	514	676	677	678	N/R	459	457	1040	291	
2007	V8	241	4.0	PACIFICA	401	402	403	512	512	514	676	677	678	N/R	459	457	1040	291	
05-07	V8	230	3.8	PACIFICA	401	402	403	512	512	514	676	677	678	N/R	459	457	1040	291	
07-94	V6	230	3.8	TOWN & COUNTRY	401	402	403	512	512	514	676	677	678	N/R	459	457	1040	291	
93-91	V6	230	3.8	NEW YORKER, IMPERIAL	401	402	403	512	512	514	676	677	678	N/R	459	457	1040	291	
83-78	L6	225	3.7	ALL MODELS	401	402	403	512	512	514	676	677	678	N/R	459	457	1040	291	
06-05	V6	215	3.5	PACIFICA	401	402	403	512	512	514	676	677	678	N/R	459	457	1040	291	
03-93	V6	215	3.5	ALL MODELS	401	402	403	512	512	514	676	677	678	N/R	459	457	1040	291	
07-90	V6	201	3.3	ALL MODELS, TOWN & COUNTRY, VOYAGER	401	402	403	512	512	514	676	677	678	N/R	459	457	1040	291	
01-98	V6	197	3.2	CONCORDE, INTREPID	401	402	403	512	512	514	676	677	678	N/R	459	457	1040	291	
03-98	V6	181	3.0	ALL MODELS	401	402	403	512	512	514	676	677	678	N/R	459	457	1040	291	
03-98	V6	167	2.7	CONCORDE, INTREPID	401	402	403	512	512	514	676	677	678	N/R	459	457	1040	291	
89-82	L4	156	2.6	ALL MODELS	401	402	403	512	512	514	676	677	678	N/R	459	457	457	291	
00-86	L4	153	2.5	ALL MODELS	401	402	403	512	512	514	676	677	678	N/R	459	457	457	291	
03-95	L4	148	2.4	ALL MODELS	401	402	403	512	512	514	676	677	678	N/R	459	457	457	291	
93-82	L4	135	2.2	ALL MODELS	401	402	403	512	512	514	676	677	678	N/R	459	457	457	291	
00-95	L4	122	2.0	ALL MODELS	401	402	403	512	512	514	676	677	678	N/R	459	457	457	291	
<b>DODGE CARS AND MINI VANS</b>																			
78-66	V8	440	7.2	ALL MODELS	403	404	405	512	514	516	677	678	679	N/R	459	457	1040	291	
71-63	V8	426	7.0	ALL MODELS	403	404	405	512	514	516	677	678	679	N/R	459	457	1040	291	
78-72	V8	400	6.6	ALL MODELS	403	404	405	512	514	516	677	678	679	N/R	459	457	1040	291	
71-60	V8	383	6.3	ALL MODELS	403	404	405	512	514	516	677	678	679	N/R	459	457	1040	291	

(1) Remote filter mount kit is optional unless otherwise noted.

# TRANSMISSION/ENGINE OIL COOLERS

## Application Guide

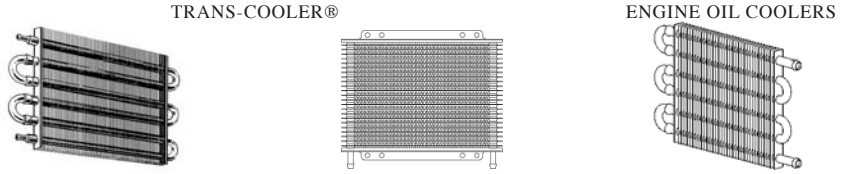

YEAR	TYPE	CID	ENGINE LITERS (VIN)	APPLICATION	ULTRA-COOL®			HIGH PERFORMANCE			RAPID-COOL®			REQUIRED TRANS FITTING KIT		TRANS COOL NOTE			REMOTE ENGINE KIT (1)		COOLER NOTE	
					LIGHT DUTY	MEDIUM DUTY	HEAVY DUTY	LIGHT DUTY	MEDIUM DUTY	HEAVY DUTY	LIGHT DUTY	MEDIUM DUTY	HEAVY DUTY	LIGHT DUTY	MEDIUM DUTY	HEAVY DUTY	LIGHT DUTY	MEDIUM DUTY	HEAVY DUTY			
<b>DODGE CARS AND MINI VANS (Cont'd)</b>																						
64-61	V8	361	5.9	ALL MODELS	403	404	405	512	514	516	677	678	679	N/R		459	457	1040	291			
80-68	V8	360	5.9	ALL MODELS	403	404	405	512	514	516	677	678	679	N/R		459	457	1040	291			
73-68	V8	340	5.6	ALL MODELS	403	404	405	512	514	516	677	678	679	N/R		459	457	1040	291			
89-60	V8	318	5.2	ALL MODELS	401	402	403	512	512	514	676	677	678	N/R		459	457	1040	291			
69-64	V8	273	4.5	ALL MODELS	401	402	403	512	512	514	676	677	678	N/R		459	457	1040	291			
03-94	V6	230	3.8	CARAVAN & GRAND CARAVAN	401	402	403	512	512	514	676	677	678	N/R		459	457	1040	291			
83-60	L6	225	3.7	ALL MODELS	401	402	403	512	512	514	676	677	678	N/R		459	457	1040	291			
07-93	V6	215	3.5	INTREPID & CARAVANS	401	402	403	512	512	514	676	677	678	N/R		459	457	1040	291			
07-90	V6	201	3.3	ALL MODELS & CARAVANS	401	402	403	512	512	514	676	677	678	N/R		459	457	1040	291			
01-98	V6	197	3.2	INTREPID	401	402	403	512	512	514	676	677	678	N/R		459	457	1040	291			
74-70	L6	198	3.2	ALL MODELS	401	402	403	512	512	514	676	677	678	N/R		459	457	1040	291			
03-97	V6	181	3.0	ALL MODELS	401	402	403	512	512	514	676	677	678	N/R		459	457	1040	291			
69-60	L6	170	2.8	ALL MODELS	401	402	403	512	512	514	676	677	678	N/R		459	457	1040	291			
03-97	V6	167	2.7	ALL MODELS	401	402	403	512	512	514	676	677	678	N/R		459	457	1040	291			
87-78	L4	156	2.6	ALL MODELS	401	402	403	512	512	514	676	677	678	N/R		459	457	457	291			
00-86	L4	153	2.5	ALL MODELS	401	402	403	512	512	514	676	677	678	N/R		459	457	457	291			
07-92	L4	148	2.4	ALL MODELS	401	402	403	512	512	514	676	677	678	N/R		459	457	457	291			
93-81	L4	135	2.2	ALL MODELS	401	402	403	512	512	514	676	677	678	N/R		459	457	457	291			
03-84	L4	122	2.0	ALL MODELS	401	402	403	512	512	514	676	677	678	N/R		459	457	457	291			
77-74	L4	122	2.0	ALL MODELS	401	402	403	512	512	514	676	677	678	N/R		459	457	457	291			
94-89	L4	112	1.8	ALL MODELS	401	402	403	512	512	514	676	677	678	N/R		459	457	457	291			
83-78	L4	104	1.7	ALL MODELS	401	402	403	512	512	514	676	677	678	N/R		459	457	457	291			
90-71	L4	98	1.6	ALL MODELS	401	402	403	512	512	514	676	677	678	N/R		459	457	457	291			
94-85	L4	90	1.5	ALL MODELS	401	402	403	512	512	514	676	677	678	N/R		459	457	457	291			
84-79	L4	86	1.4	ALL MODELS	401	402	403	512	512	514	676	677	678	N/R		459	457	457	291			
<b>DODGE TRUCKS AND SUVs</b>																						
07-04	V10	505	8.3	RAM SRT10	-	-	-	-	-	-	-	-	-	-	-	-	1040	1040	291			
05-94	V10	492	8.0	RAM 2500-3500 PICKUPS	-	-	-	-	-	-	-	-	-	-	-	-	1040	1040	291			
78-73	V8	440	7.2	ALL TRUCK & MOTORHOME MODELS	404	405	1015	514	516	516	677	678	679	N/R		459	457	1040	291	(8)		
78-71	V8	400	6.6	ALL TRUCK MODELS	403	404	405	512	514	516	677	678	679	N/R		459	457	1040	291			
67-63	V8	383	6.4	ALL TRUCK MODELS	403	404	405	512	514	516	677	678	679	N/R		459	457	1040	291			
71-68	V8	383	6.3	ALL TRUCK MODELS	403	404	405	512	514	516	677	678	679	N/R		459	457	1040	291			
07-89	L6	359	5.9	CUMMINS TURBO DIESEL	-	-	-	-	-	-	-	-	-	-	-	-	-	-	-			
03-99	V8	360	5.9	ALL GAS MODELS	403	404	405	512	514	516	677	678	679	398 or 391		459	457	1040	291			
98-68	V8	360	5.9	ALL TRUCK & MOTORHOME MODELS	403	404	405	512	514	516	677	678	679	N/R		459	457	1040	291			
07-03	V8	350	5.7	DURANGO, & RAM TRUCKS	403	404	405	512	514	516	677	678	679	N/R		-	-	-	-			
03-99	V8	318	5.2	ALL TRUCK & MOTORHOME MODELS	403	404	405	512	514	516	677	678	679	398 or 391		459	457	1040	291			
98-94	V8	318	5.2	ALL TRUCK MODELS	403	404	405	512	514	516	677	678	679	392 (17)		459	457	1040	291			
93-60	V8	318	5.2	ALL TRUCK & MOTORHOME MODELS	403	404	405	512	514	516	677	678	679	392 (17)		459	457	1040	291			
07-99	V8	285	4.7	DAKOTA, DURANGO, & RAM TRUCKS	403	404	405	512	514	516	677	678	679	N/R		459	457	1040	291			
05-99	V6	239	3.9	DAKOTA, DURANGO, & RAM TRUCKS	401	402	403	512	512	514	676	677	678	396		459	457	1040	291			

(1) Remote filter mount kit is optional unless otherwise noted.  
 (17) 1994 and later vehicles with rubber trans lines require splicer kit #392.

(8) Remote kit is required for 440 engines in van applications.

# TRANSMISSION/ENGINE OIL COOLERS

## Application Guide

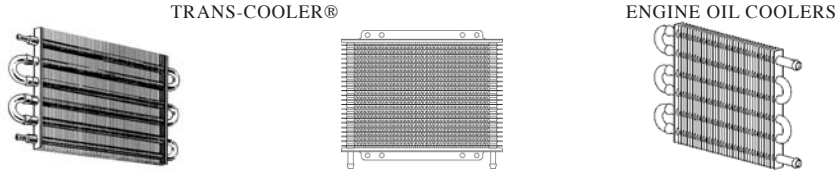

ULTRA-COOL® HIGH PERFORMANCE RAPID-COOL®

YEAR	TYPE	CID	ENGINE LITERS (VIN)	APPLICATION	ULTRA-COOL®			HIGH PERFORMANCE			RAPID-COOL®			REQUIRED FITTING KIT	TRANS COOLR NOTE	REMOTE ENGINE KIT (1)			ENGINE COOLER NOTE
					LIGHT DUTY	MEDIUM DUTY	HEAVY DUTY	LIGHT DUTY	MEDIUM DUTY	HEAVY DUTY	LIGHT DUTY	MEDIUM DUTY	HEAVY DUTY			LIGHT DUTY	MEDIUM DUTY	HEAVY DUTY	
<b>DODGE TRUCKS AND SUVS (Cont'd)</b>																			
98-94	V6	239	3.9	ALL TRUCK MODELS	401	402	403	512	512	514	676	677	678	392 (17)		459	457	1040	291
93-87	V6	239	3.9	ALL TRUCK MODELS	401	402	403	512	512	514	676	677	678	N/R		459	457	1040	291
07-04	V6	226	3.7	DURANGO, DAKOTA	401	402	403	512	512	514	676	677	678	N/R		459	457	1040	291
05-02	V6	225	3.7	RAM PICKUPS	401	402	403	512	512	514	676	677	678	N/R		459	457	1040	291
87-60	L6	225	3.7	ALL TRUCK MODELS	401	402	403	512	512	514	676	677	678	N/R		459	457	1040	291
91-87	V6	181	3.0	MINI RAM, RAM 50	401	402	403	512	512	514	676	677	678	N/R		459	457	1040	291
89-79	L4	156	2.6	D 50, MINI RAM, RAIDER	401	402	403	512	512	514	676	677	678	N/R		459	457	1040	291
02-87	L4	153	2.5	DAKOTA, MINI RAM	401	402	403	512	512	514	676	677	678	N/R		459	457	1040	291
93-90	L4	148	2.4	RAM 50	401	402	403	512	512	514	676	677	678	N/R		459	457	1040	291
85-83	L4	143	2.3	RAM 50 DIESEL	401	402	403	512	512	514	676	677	678	N/R		-	-	-	-
88-82	L4	135	2.2	MINI RAM, RAMPAGE	401	402	403	512	512	514	676	677	678	N/R		459	457	1040	291
89-79	L4	122	2.0	RAM 50, D 50	401	402	403	512	512	514	676	677	678	N/R		459	457	1040	291
<b>DODGE VANS</b>																			
79-74	V8	440	7.2	ALL VAN & MOTORHOME MODELS	404	405	1015	514	516	516	677	678	679	N/R		459	457	1040	291 (8)
78-71	V8	400	6.6	ALL TRUCK MODELS	403	404	405	512	514	516	677	678	679	N/R		459	457	1040	291
04-99	V8	360	5.9	ALL GAS MODELS	403	404	405	512	514	516	677	678	679	396		459	457	1040	291
98-71	V8	360	5.9	ALL VAN & MOTORHOME MODELS	403	404	405	512	514	516	677	678	679	N/R		459	457	1040	291
04-99	V8	318	5.2	ALL VAN MODELS	403	404	405	512	514	516	677	678	679	396		459	457	1040	291
98-94	V8	318	5.2	ALL VAN MODELS	403	404	405	512	514	516	677	678	679	392 (17)		459	457	1040	291
93-67	V8	318	5.2	ALL VAN & MOTORHOME MODELS	403	404	405	512	514	516	677	678	679	N/R		459	457	1040	291
67-64	V8	273	4.5	ALL VAN MODELS	403	404	405	512	514	516	677	678	679	N/R		459	457	1040	291
04-99	V6	239	3.9	ALL VAN MODELS	401	402	403	512	512	514	676	677	678	396		459	457	1040	291
98-94	V6	239	3.9	ALL VAN MODELS	401	402	403	512	512	514	676	677	678	392 (17)		459	457	1040	291
93-87	V6	239	3.9	ALL VAN MODELS	401	402	403	512	512	514	676	677	678	N/R		459	457	1040	291
87-64	L6	225	3.7	ALL VAN MODELS	401	402	403	512	512	514	676	677	678	N/R		459	457	1040	291
71-70	L6	198	3.2	ALL VAN MODELS	401	402	403	512	512	514	676	677	678	N/R		459	457	1040	291
69-64	L6	170	2.8	ALL VAN MODELS	401	402	403	512	512	514	676	677	678	N/R		459	457	1040	291
89-79	L4	156	2.6	ALL VAN MODELS	401	402	403	512	512	514	676	677	678	N/R		459	457	1040	291
<b>EAGLE (Including AMC Eagle)</b>																			
88-80	L6	258	4.2	ALL MODELS	401	402	403	512	512	514	676	677	678	N/R		459	457	-	291
97-93	V6	215	3.5	ALL MODELS	401	402	403	512	512	514	676	677	678	N/R		459	457	1040	291
97-93	V6	201	3.3	ALL MODELS	401	402	403	512	512	514	676	677	678	N/R		459	457	1040	291
92-88	V6	184	3.0	ALL MODELS	401	402	403	512	512	514	676	677	678	N/R		459	457	457	291
89-88	L4	151	2.5	ALL MODELS	401	402	403	512	512	514	676	677	678	N/R		459	457	457	291 (2)
96-92	L4	144	2.4	ALL MODELS	401	402	403	512	512	514	676	677	678	N/R		459	457	-	291
89-88	L4	132	2.2	ALL MODELS	401	402	403	512	512	514	676	677	678	N/R		459	457	-	291
98-89	L4	122	2.0	ALL MODELS	401	402	403	512	512	514	676	677	678	N/R		459	457	-	291
96-93	L4	107	1.8	ALL MODELS	401	402	403	512	512	514	676	677	678	N/R		459	457	-	291
90-89	L4	98	1.6	ALL MODELS	401	402	403	512	512	514	676	677	678	N/R		459	457	-	291
96-89	L4	90	1.5	ALL MODELS	401	402	403	512	512	514	676	677	678	N/R		459	457	-	291

(1) Remote filter mount kit is optional unless otherwise noted.

(8) Remote kit is required for 440 engines in van applications.

(2) Check for 2" oil filter clearance, some vehicles require remote kit #291.

(17) 1994 and later vehicles with rubber trans lines require splicer kit #392.

# TRANSMISSION/ENGINE OIL COOLERS

## Application Guide

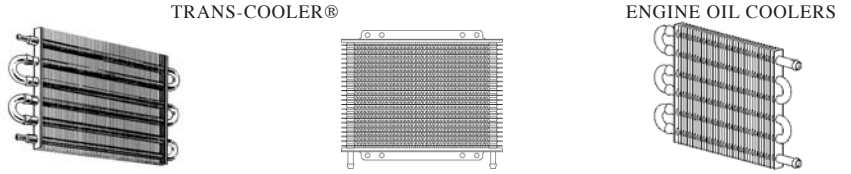

YEAR	TYPE	CID	ENGINE LITERS (VIN)	APPLICATION	ULTRA-COOL®			HIGH PERFORMANCE			RAPID-COOL®			REQUIRED TRANS FITTING KIT		TRANS COOL NOTE		REMOTE ENGINE KIT (1)		COOLER NOTE
					LIGHT DUTY	MEDIUM DUTY	HEAVY DUTY	LIGHT DUTY	MEDIUM DUTY	HEAVY DUTY	LIGHT DUTY	MEDIUM DUTY	HEAVY DUTY	LIGHT DUTY	MEDIUM DUTY	HEAVY DUTY	LIGHT DUTY	MEDIUM DUTY	HEAVY DUTY	
78-72	V8	460	7.5	ALL MODELS	403	404	405	512	514	516	677	678	679	N/R		459	1040	1040	291	
73-68	V8	429	7.0	ALL MODELS	403	404	405	512	514	516	677	678	679	N/R		459	1040	1040	291	
70-66	V8	428	7.0	ALL MODELS	403	404	405	512	514	516	677	678	679	N/R		459	1040	1040	291	
69-63	V8	427	7.0	ALL MODELS	403	404	405	512	514	516	677	678	679	N/R		459	1040	1040	291	
78-71	V8	400	6.6	ALL MODELS	403	404	405	512	514	516	677	678	679	N/R		459	1040	1040	291	
75-61	V8	390	6.4	ALL MODELS	403	404	405	512	514	516	677	678	679	N/R		459	1040	1040	291	
75-73	V8	360	5.9	ALL MODELS	401	402	403	512	512	514	676	677	678	N/R		459	457	1040	291	(2)
91-83	V8	351	5.8	ALL MODELS	401	402	403	512	512	514	676	677	678	252 or 394 (4)		459	457	1040	291	(2)
82-69	V8	351	5.8	ALL MODELS	401	402	403	512	512	514	676	677	678	N/R		459	457	1040	291	(2)
95-90	V8	302	5.0	MUSTANG	-	-	-	-	-	-	-	-	-	- (5)		459	457	1040	291	(2)
89-68	V8	302	5.0	MUSTANG	401	402	403	512	512	514	676	677	678	252 or 394 (4)		459	457	1040	291	(2)
93-83	V8	302	5.0	ALL EXCEPT MUSTANG	401	402	403	512	512	514	676	677	678	252 or 394 (4)		459	457	1040	291	(2)
82-68	V8	302	5.0	ALL MODELS	401	402	403	512	512	514	676	677	678	252 or 394 (4)		459	457	1040	291	(2)
68-63	V8	289	4.7	ALL MODELS	401	402	403	512	512	514	676	677	678	N/R		459	457	1040	291	(2)
07-92	V8	281	4.6	CROWN VICTORIA	401	402	403	512	512	514	676	677	678	252 or 394 (4)		-	-	-	-	
07-96	V8	281	4.6	MUSTANG	401	402	403	512	512	514	676	677	678	252 or 394 (4)		459	457	1040	-	
82-80	V8	255	4.2	ALL MODELS	401	402	403	512	512	514	676	677	678	N/R		459	457	1040	291	(2)
80-69	L6	250	4.1	ALL MODELS	401	402	403	512	512	514	676	677	678	N/R		459	457	1040	291	
07-05	V6	245	4.0	MUSTANG	403	404	404	512	514	514	676	677	678	395		459	457	1040	291	
67-65	L6	240	4.0	ALL MODELS	401	402	403	512	512	514	676	677	678	N/R		459	457	1040	291	
72-68	L6	240	3.9	ALL MODELS	401	402	403	512	512	514	676	677	678	N/R		459	457	1040	291	
04-94	V6	232	3.8	MUSTANG	401	402	403	512	512	514	676	677	678	252 or 394 (4)		459	457	1040	291	
86-83	V6	232	3.8	MUSTANG	401	402	403	512	512	514	676	677	678	252 or 394 (4)		459	457	1040	291	
95-88	V6	182	3.8	TAURUS	401	402	403	512	512	514	676	677	678	252 or 394 (4)		459	459	457	291	(2)
97-82	V6	232	3.8	THUNDERBIRD	401	402	403	512	512	514	676	677	678	252 or 394 (4)		459	457	1040	291	
64-60	L6	223	3.7	ALL MODELS	401	402	403	512	512	514	676	677	678	N/R		459	457	1040	291	
99-96	V8	207	3.4	TAURUS SHO	-	-	-	-	-	-	-	-	-	-		-	-	-	-	
83-63	L6	200	3.3	ALL MODELS	401	402	403	512	512	514	676	677	678	N/R		459	457	1040	291	
95-93	V6	198	3.2	TAURUS	401	402	403	512	512	514	676	677	678	390		-	-	-	-	
05-86	V6	182	3.0	TAURUS	401	402	403	512	512	514	676	677	678	252 or 394 (4)		459	459	457	291	(2)
79-74	V6	171	2.8	MUSTANG, MUSTANG II, PINTO	401	402	403	512	512	514	676	677	678	N/R		459	459	457	291	(2)
72-60	L6	170	2.8	ALL MODELS	401	402	403	512	512	514	676	677	678	N/R		459	459	457	291	(2)
91-86	L4	153	2.5	TAURUS	401	402	403	512	512	514	676	677	678	252 or 394 (4)		459	459	457	291	(2)
00-93	V6	152	2.5	CONTOUR, PROBE	401	402	403	512	512	514	676	677	678	390		459	457	457	-	(18)
94-83	L4	140	2.3	ALL MODELS	401	402	403	512	512	514	676	677	678	252 or 394 (4)		459	459	457	291	(2)
82-74	L4	140	2.3	ALL MODELS	401	402	403	512	512	514	676	677	678	N/R		459	459	457	291	(2)
92-89	L4	133	2.2	PROBE	401	402	403	512	512	514	676	677	678	N/R		-	-	-	-	
00-95	L4	122	2.0	CONTOUR	401	402	403	512	512	514	676	677	678	390		459	457	457	291	
03-97	L4	122	2.0	ESCORT, ZX2	401	402	403	512	512	514	676	677	678	390		459	457	457	291	
05-00	L4	122	2.0	FOCUS	401	402	403	512	512	514	676	677	678	390		459	457	457	291	
74-71	L4	122	2.0	MUSTANG II, PINTO	401	402	403	512	512	514	676	677	678	N/R		459	457	457	291	
96-93	L4	122	2.0	PROBE	401	402	403	512	512	514	676	677	678	390		459	457	457	291	
87-84	L4	122	2.0	TEMPO, ESCORT DIESEL	401	402	403	512	512	514	676	677	678	N/R		459	457	457	291	
96-85	L4	116	1.9	ESCORT, EXP	401	402	403	512	512	514	676	677	678	N/R		459	459	457	291	
96-91	L4	110	1.8	ESCORT	401	402	403	512	512	514	676	677	678	N/R		459	459	457	291	
86-78	L4	98	1.6	ESCORT, EXP	401	402	403	512	512	514	676	677	678	N/R		459	459	457	291	

(1) Remote filter mount kit is optional unless otherwise noted.

(4) Use kit #252 with snap-in (duckbill) type trans line fittings. Use kit #394 with 1/2"-20 partial thread fittings.

(18) No remote oil filter applications for engines with 22MM oil filter thread.

(2) Check for 2" oil filter clearance, some vehicles require remote kit #291.

(5) No trans line fitting kit available.

# TRANSMISSION/ENGINE OIL COOLERS

## Application Guide

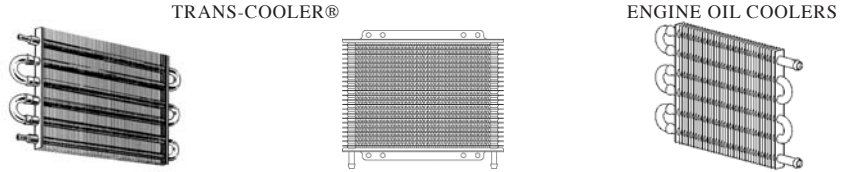

ULTRA-COOL® HIGH PERFORMANCE RAPID-COOL®

YEAR	TYPE	CID	ENGINE LITERS (VIN)	APPLICATION	ULTRA-COOL®			HIGH PERFORMANCE			RAPID-COOL®			REQUIRED TRANS FITTING KIT		REMOTE ENGINE KIT (1)		ENGINE COOLER NOTE	
					LIGHT DUTY	MEDIUM DUTY	HEAVY DUTY	LIGHT DUTY	MEDIUM DUTY	HEAVY DUTY	LIGHT DUTY	MEDIUM DUTY	HEAVY DUTY	COOL NOTE	LIGHT DUTY	MEDIUM DUTY	HEAVY DUTY		
<b>FORD TRUCKS</b>																			
97-83	V8	460	7.5	F150, 250, 350, 450 TRUCKS	404	405	1015	514	516	516	677	678	679	252 or 394	459	1040	1040	291	
79-73	V8	460	7.5	F100, 250, 350 TRUCKS	404	405	1015	514	516	516	677	678	679	N/R	459	1040	1040	291	
04-00	V8	445	7.3	DIESEL, EXCURSION	404	405	1015	514	516	516	677	678	679	395	-	-	-	-	
03-99	V8	445	7.3	DIESEL, F-250, F-350, F-450, F-550	404	405	1015	514	516	516	677	678	679	395	-	-	-	-	
98-88	V8	445	7.3	DIESEL, F250, 350, 450 TRUCKS	404	405	1015	514	516	516	677	678	679	252 or 394	-	-	-	-	
87-83	V8	414	6.9	DIESEL F250-350	404	405	1015	514	516	516	677	678	679	252 or 394	-	-	-	-	
05-00	V10	415	6.8	EXCURSION	404	405	1015	514	516	516	677	678	679	395	-	-	-	-	
07-99	V10	415	6.8	F250-550 TRUCKS	404	405	1015	514	516	516	677	678	679	395	-	-	-	-	
82-77	V8	400	6.6	F-150, 250, 350 PICKUP	403	404	405	512	514	516	677	678	679	N/R	459	459	457	291	
79-78	V8	400	6.6	BRONCO	403	404	405	512	514	516	677	678	679	N/R	459	459	457	291	
76-68	V8	390	6.4	F-100, 150, 250, 350 PICKUP	403	404	405	512	514	516	677	678	679	N/R	459	459	457	291	
07-03	V8	368	6.0	DIESEL, F-250, 350, 450, 550 PICKUP	-	-	-	-	-	-	-	-	-	-	-	-	-	-	
05-03	V8	368	6.0	DIESEL, EXCURSION	-	-	-	-	-	-	-	-	-	-	-	-	-	-	
67-64	V8	361	5.9	F350	403	404	405	512	514	516	677	678	679	N/R	459	459	457	291	
76-68	V8	360	5.9	F-100, 150, 250, 350 PICKUP	403	404	405	512	514	516	677	678	679	N/R	459	459	457	291	
67-66	V8	352	5.8	F-150, 250, 350 PICKUP	403	404	405	512	514	516	677	678	679	N/R	459	459	457	291	
96-94	V8	351	5.8	BRONCO	403	404	405	512	514	516	677	678	679	252 or 394	459	457	1040	-	(18)
93-83	V8	351	5.8	BRONCO	403	404	405	512	514	516	677	678	679	252 or 394	459	459	457	291	
82-78	V8	351	5.8	BRONCO	403	404	405	512	514	516	677	678	679	N/R	459	457	1040	291	
97-95	V8	351	5.8	F-150, 250 350 PICKUP	403	404	405	512	514	516	677	678	679	252 or 394	459	457	1040	291	(18)
94	V8	351	5.8	F-150, 250 350 PICKUP W/ ENGINE	403	404	405	512	514	516	677	678	679	252 or 394	459	457	1040	291	(18)
94	V8	351	5.8	F-150, 250 350 PICKUP W/O ENGINE	403	404	405	512	514	516	677	678	679	252 or 394	459	459	457	291	
93-83	V8	351	5.8	F-150, 250 350 PICKUP	403	404	405	512	514	516	677	678	679	252 or 394	459	459	457	291	
93	V8	351	5.8	F-150 LIGHTNING	403	404	405	512	514	516	677	678	679	252 or 394	459	457	1040	291	(18)
92-82	V8	351	5.8	F-150, 250 350 PICKUP	403	404	405	512	514	516	677	678	679	252 or 394	459	457	1040	291	(18)
81-77	V8	351	5.8	F-150, 250 350 PICKUP	403	404	405	512	514	516	677	678	679	N/R	459	457	1040	291	(18)
05-00	V8	330	5.4	EXCURSION	403	404	405	512	514	516	677	678	679	395	459	457	1040	-	(18)
07-99	V8	330	5.4	EXPEDITION	403	404	405	512	514	516	677	678	679	395	459	457	1040	-	(18)
07-03	V8	330	5.4	F-150 PICKUP	-	-	-	-	-	-	-	-	-	-	459	457	1040	-	(18)
07-03	V8	330	5.4	F-250, 350 PICKUP	403	404	405	512	514	516	677	678	679	395	459	457	1040	-	(18)
02-97	V8	330	5.4	F-250, 350 PICKUP	403	404	405	512	514	516	677	678	679	395	459	457	1040	-	(18)
99-97	V8	330	5.4	F-150 PICKUP	403	404	405	512	514	516	677	678	679	395	459	457	1040	-	(18)
96-82	V8	302	5.0	BRONCO	403	404	405	512	514	516	677	678	679	252 or 394	459	459	457	291	
81-68	V8	302	5.0	BRONCO	403	404	405	512	514	516	677	678	679	252 or 394	459	459	457	291	
01-96	V8	302	5.0	EXPLORER	403	404	405	512	514	516	677	678	679	395	459	457	1040	-	(18)
96-82	V8	302	5.0	F-150, 250, 350 PICKUP	403	404	405	512	514	516	677	678	679	252 or 394	459	457	1040	291	(2)
81-69	V8	302	5.0	F-150, 250, 350 PICKUP	403	404	405	512	514	516	677	678	679	N/R	459	457	1040	291	(2)
96-82	L6	300	4.9	F-150, 250, 350 PICKUP	403	404	405	512	514	516	677	678	679	252 or 394	459	457	1040	291	(2)
81-85	L6	300	4.9	F-150, 250, 350 PICKUP	403	404	405	512	514	516	677	678	679	252 or 394	459	457	1040	291	(2)
68-66	V8	289	4.7	BRONCO	403	404	405	512	514	516	677	678	679	N/R	459	457	1040	291	

(1) Remote filter mount kit is optional unless otherwise noted.  
 (18) No remote oil filter applications for engines with 22MM oil filter thread.

(2) Check for 2" oil filter clearance, some vehicles require remote kit #291.

# TRANSMISSION/ENGINE OIL COOLERS

## Application Guide

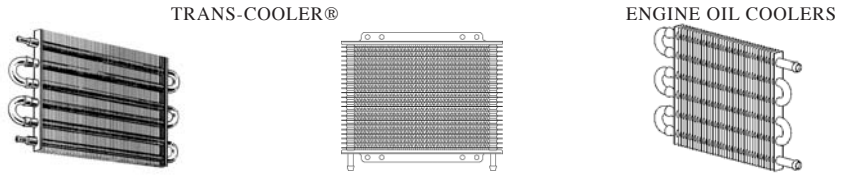

YEAR	TYPE	CID	ENGINE LITERS (VIN)	APPLICATION	ULTRA-COOL®			HIGH PERFORMANCE			RAPID-COOL®			REQUIRED TRANS FITTING KIT		TRANS COOL NOTE			REMOTE ENGINE KIT (1)		ENGINE COOLER NOTE	
					LIGHT DUTY	MEDIUM DUTY	HEAVY DUTY	LIGHT DUTY	MEDIUM DUTY	HEAVY DUTY	LIGHT DUTY	MEDIUM DUTY	HEAVY DUTY	LIGHT DUTY	MEDIUM DUTY	HEAVY DUTY	LIGHT DUTY	MEDIUM DUTY	HEAVY DUTY			
<b>FORD TRUCKS (Cont'd)</b>																						
07-02	V8	281	4.6	EXPLORER	-	-	-	-	-	-	-	-	-	-	-	-	459	457	1040	-	(18)	
07-99	V8	281	4.6	EXPEDITION	403	404	405	512	514	516	677	678	679	395	(19)	459	457	1040	-	(18)		
98-97	V8	281	4.6	EXPEDITION	403	404	405	512	514	516	677	678	679	394 or 395		459	457	1040	-	(18)		
07-03	V8	281	4.6	F-150, 250 PICKUP	403	404	405	512	514	516	677	678	679	395		459	457	1040	-	(18)		
99-97	V8	281	4.6	F-250 PICKUP	403	404	405	512	514	516	677	678	679	394		459	457	1040	-	(18)		
07-97	V8	281	4.6	F-150 PICKUP	403	404	405	512	514	516	677	678	679	394		459	457	1040	-	(18)		
99-97	V6	256	4.2	F-250 PICKUP	403	404	405	512	514	516	677	678	679	394 or 395 (19)		459	457	1040	-	(18)		
07-03	V6	256	4.2	F-150 PICKUP	-	-	-	-	-	-	-	-	-	-	-	459	457	1040	-	(18)		
02-97	V6	256	4.2	F-150 PICKUP	403	404	405	512	514	516	677	678	679	394 or 395 (19)		459	457	1040	291			
82-81	V8	255	4.2	F-100 PICKUP	403	404	404	512	514	514	677	678	679	N/R		459	457	1040	291			
07-98	V6	245	4.0	EXPLORER	403	404	404	512	514	514	676	677	678	395		459	457	1040	291			
01-91	V6	245	4.0	EXPLORER	403	404	404	512	514	514	676	677	678	390		459	457	1040	291			
07-98	V6	245	4.0	RANGER	403	404	404	512	514	514	676	677	678	395		459	457	1040	291			
67-66	L6	240	4.0	BRONCO	403	404	404	512	514	514	676	677	678	N/R		459	457	1040	291			
67-65	L6	240	4.0	F-250, 350 PICKUP	403	404	404	512	514	514	676	677	678	N/R		459	457	1040	291			
74-68	L6	240	3.9	F-150, 250, 350 PICKUP	403	404	404	512	514	514	676	677	678	N/R		459	457	1040	291			
83-82	V6	232	3.8	F-100, 250 PICKUP	403	404	404	512	514	514	676	677	678	N/R		459	457	1040	291			
07-02	V6	182	3.0	ESCAPE	403	404	404	512	514	514	676	677	678	N/R		-	-	-	-			
07-98	V6	182	3.0	RANGER	403	404	404	512	514	514	676	677	678	395		459	457	1040	291			
97-91	V6	182	3.0	RANGER	403	404	404	512	514	514	676	677	678	395		459	457	1040	291			
90-92	V6	171	2.8	BRONCO II	403	404	404	512	514	514	676	677	678	390		459	457	1040	291			
92-86	V6	177	2.9	RANGER	403	404	404	512	514	514	676	677	678	252 or 390		459	457	1040	291			
85-83	V6	171	2.8	RANGER, BRONCO II	403	404	404	512	514	514	676	677	678	252 or 394		459	457	1040	291			
72-68	L6	170	2.8	BRONCO	401	402	403	512	512	514	676	677	678	N/R		459	457	1040	291			
01-98	L4	150	2.5	RANGER	401	402	403	512	512	514	676	677	678	395		459	457	1040	291			
07-05	L4	140	2.3	ESCAPE	401	402	403	512	514	514	676	677	678	N/R		-	-	-	-			
07-01	L4	140	2.3	RANGER	401	402	403	512	512	514	676	677	678	252 or 390		459	457	1040	291			
97-90	L4	140	2.3	RANGER	401	402	403	512	512	514	676	677	678	252 or 390		459	457	1040	291			
89-83	L4	140	2.3	RANGER	401	402	403	512	512	514	676	677	678	252 or 394		459	457	1040	291			
87-83	L4	140	2.3	RANGER DIESEL	401	402	403	512	512	514	676	677	678	252 or 394		-	-	-	-			
04-01	L4	122	2.0	ESCAPE	401	402	403	512	514	514	676	677	678	N/R		-	-	-	-			
89-79	L4	122	2.0	RANGER	401	402	403	512	512	514	676	677	678	N/R		459	457	1040	291			
<b>FORD VANS</b>																						
96-83	V8	460	7.5	E250 & E350 INCLUDING MOTORHOMES	404	405	1015	514	516	516	677	678	679	252 or 394		459	1040	1040	291			
82-75	V8	460	7.5	E250 & E350 INCLUDING MOTORHOMES	404	405	1015	514	516	516	677	678	679	N/R		459	1040	1040	291			
80-75	V8	460	7.5	E100, E150 ECONOLINE	403	404	405	512	514	516	677	678	679	N/R		459	1040	1040	291			
03-96	V8	445	7.3	E SUPER DUTY	404	405	1015	514	516	516	677	678	679	252 or 394		-	-	-	-			
2003	V8	445	7.3	E-450 ECONOLINE	404	405	1015	514	516	516	677	678	679	252 or 394		-	-	-	-			
91-88	V8	445	7.3	E 250 ECONOLINE, CLUB WAGON	404	405	1015	514	516	516	677	678	679	252 or 394		-	-	-	-			
03-88	V8	445	7.3	E350 ECONOLINE	404	405	1015	514	516	516	677	678	679	252 or 394		-	-	-	-			
07-03	V10	415	6.8	E450 ECONOLINE	404	405	1015	514	516	516	677	678	679	394		-	-	-	-			
07-97	V10	415	6.8	E350 ECONOLINE	404	405	1015	514	516	516	677	678	679	394		-	-	-	-			
1997	V10	415	6.8	E250 ECONOLINE	404	405	1015	514	516	516	677	678	679	394		-	-	-	-			
07-97	V10	415	6.8	E SUPER DUTY	404	405	1015	514	516	516	677	678	679	394		-	-	-	-			

(1) Remote filter mount kit is optional unless otherwise noted.

(18) No remote oil filter applications for engines with 22MM oil filter thread.

(19) Use kit #395 on vehicles with 5/8"-18 thread on trans line fitting. Use kit #394 with 1/2"-20 thread fittings.

# TRANSMISSION/ENGINE OIL COOLERS

## Application Guide

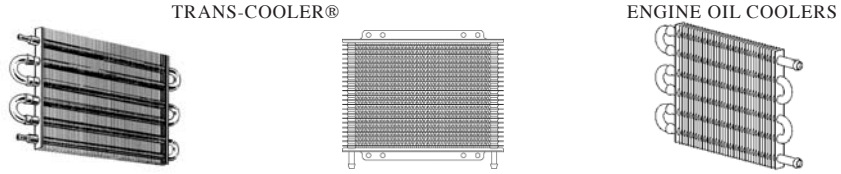

ULTRA-COOL® HIGH PERFORMANCE RAPID-COOL®

YEAR	TYPE	CID	ENGINE LITERS (VIN)	APPLICATION	ULTRA-COOL®			HIGH PERFORMANCE			RAPID-COOL®			REQUIRED TRANS FITTING KIT		REMOLE ENGINE KIT (1)		COOLER NOTE
					LIGHT DUTY	MEDIUM DUTY	HEAVY DUTY	LIGHT DUTY	MEDIUM DUTY	HEAVY DUTY	LIGHT DUTY	MEDIUM DUTY	HEAVY DUTY	COOLR NOTE	LIGHT DUTY	MEDIUM DUTY	HEAVY DUTY	
<b>FORD VANS (Cont'd)</b>																		
07-03	V8	368	6.0	DIESEL, E250, 350, 450, 550	-	-	-	-	-	-	-	-	-	-	-	-	-	-
87-83	V8	414	6.9	E250 & E350 ECONOLINE	404	405	1015	514	516	516	677	678	679	252 or 394	-	-	-	-
82-80	V8	400	6.6	E150, E250 & E350 ECONOLINE	403	404	405	512	514	516	677	678	679	252 or 394	459	1040	1040	291
96-94	V8	351	5.8	E250 & E350 W/ ENGINE OIL COOLER	403	404	405	512	514	516	677	678	679	252 or 394	459	457	1040	- (18)
96-94	V8	351	5.8	E250 & E350 W/O ENGINE OIL COOLER	403	404	405	512	514	516	677	678	679	252 or 394	459	459	457	291
93-83	V8	351	5.8	E250 & E350 ECONOLINE	403	404	405	512	514	516	677	678	679	252 or 394	459	459	457	291
82-75	V8	351	5.8	E150, E250 & E350 ECONOLINE	403	404	405	512	514	516	677	678	679	N/R	459	459	457	291
07-03	V8	329	5.4	E450 ECONOLINE	403	404	405	512	514	516	677	678	679	252 or 394	459	459	457	291
07-97	V8	329	5.4	E SUPER DUTY, E150, E250 & E350 ECONOLINE	403	404	405	512	514	516	677	678	679	252 or 394	459	459	457	291
96-82	V8	302	5.0	E150, E250 & E350 ECONOLINE	403	404	405	512	514	516	677	678	679	252 or 394	459	459	457	291
81-75	V8	302	5.0	E150, E250 & E350 ECONOLINE	403	404	405	512	514	516	677	678	679	N/R	459	459	457	291
83-68	V8	302	5.0	E100, E200 & E300 ECONOLINE	403	404	405	512	514	516	677	678	679	N/R	459	459	457	291
96-82	L6	300	4.9	E150, E250 & E350 ECONOLINE	403	404	405	512	514	516	677	678	679	252 or 394	459	459	457	291
81-75	L6	300	4.9	E150, E250 & E350 ECONOLINE	403	404	405	512	514	516	677	678	679	N/R	459	459	457	291
81-85	L6	300	4.9	E100, E200 & E300 ECONOLINE	403	404	405	512	514	516	677	678	679	N/R	459	459	457	291
07-97	V8	281	4.6	E150 & E250 ECONOLINE	403	404	405	512	514	516	677	678	679	252 or 394	-	-	-	-
03-97	V6	256	4.2	E150 & E250 ECONOLINE	403	404	405	512	514	516	677	678	679	252 or 394	459	459	457	291
97-90	V6	245	4.0	AEROSTAR	403	404	405	512	514	516	677	678	679	252 or 390	459	459	457	291
74-68	L6	240	3.9	E100, E200 & E300 ECONOLINE	403	404	405	512	514	516	677	678	679	N/R	459	459	457	291
03-98	V6	232	3.8	WINDSTAR	-	-	-	-	-	-	-	-	-	(5)	459	459	457	291
00-95	V6	182	3.0	WINDSTAR	-	-	-	-	-	-	-	-	-	(5)	459	459	457	291
97-86	V6	182	3.0	AEROSTAR	403	404	405	512	514	516	677	678	679	252 or 395	459	459	457	291
86	V6	171	2.8	AEROSTAR	403	404	405	512	514	516	677	678	679	252 or 395	459	459	457	291
70-68	L6	170	2.8	E100, E200 & E300 ECONOLINE	403	404	405	512	514	516	677	678	679	N/R	459	459	457	291
67-62	L6	170	2.8	ECONOLINE	403	404	405	512	514	516	677	678	679	N/R	459	459	457	291
66-61	L6	144	2.4	ECONOLINE	403	404	405	512	514	516	677	678	679	N/R	459	459	457	291
87-86	L4	140	2.3	AEROSTAR	403	404	405	512	514	516	677	678	679	252 or 395	459	459	457	291
<b>HONDA CARS</b>																		
04-98	V6	184	3.0	ACCORD	401	402	403	512	512	514	676	677	678	N/R	-	-	-	-
97-95	V6	166	2.7	ACCORD	401	402	403	512	512	514	676	677	678	N/R	-	-	-	-
04-03	L4	147	2.4	ACCORD	401	402	403	512	512	514	676	677	678	N/R	-	-	-	-
02-98	L4	141	2.3	ACCORD	401	402	403	512	512	514	676	677	678	N/R	-	-	-	-
96-92	L4	141	2.3	PRELUDE	401	402	403	512	512	514	676	677	678	N/R	-	-	-	-
01-92	L4	135	2.2	PRELUDE	401	402	403	512	512	514	676	677	678	N/R	-	-	-	-
91-90	L4	129	2.1	PRELUDE	401	402	403	512	512	514	676	677	678	N/R	-	-	-	-

(1) Remote filter mount kit is optional unless otherwise noted.  
 (18) No remote oil filter applications for engines with 22MM oil filter thread.

(5) No trans line fitting kit available.

# TRANSMISSION/ENGINE OIL COOLERS

## Application Guide

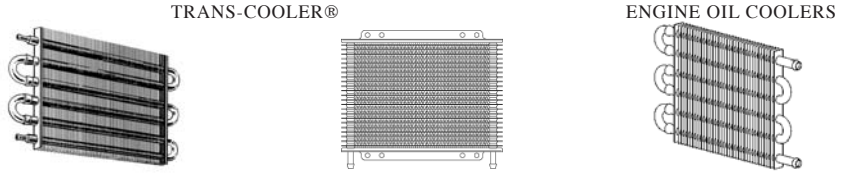

YEAR	TYPE	CID	ENGINE LITERS (VIN)	APPLICATION	ULTRA-COOL®			HIGH PERFORMANCE			RAPID-COOL®			REQUIRED TRANS FITTING KIT		REMOTE ENGINE KIT (1)		ENGINE COOLER NOTE
					LIGHT DUTY	MEDIUM DUTY	HEAVY DUTY	LIGHT DUTY	MEDIUM DUTY	HEAVY DUTY	LIGHT DUTY	MEDIUM DUTY	HEAVY DUTY	TRANS COOLR NOTE	LIGHT DUTY	MEDIUM DUTY	HEAVY DUTY	
<b>HONDA CARS (Cont'd)</b>																		
03-00	L4	123	2.0	S2000	401	402	403	512	512	514	676	677	678	N/R	-	-	-	-
91-85	L4	123	2.0	PRELUDE	401	402	403	512	512	514	676	677	678	N/R	-	-	-	-
89-86	L4	123	2.0	ACCORD	401	402	403	512	512	514	676	677	678	N/R	-	-	-	-
87-79	L4	111	1.8	PRELUDE	401	402	403	512	512	514	676	677	678	N/R	-	-	-	-
<b>HONDA TRUCKS AND VANS</b>																		
06-05	V6	215	3.5	RIDGELINE, RT, RTL	401	402	403	512	512	514	676	677	678	N/R	459	459	457	291
05-03	V6	215	3.5	PILOT	401	402	403	512	512	514	676	677	678	N/R	459	459	457	291
05-99	V6	215	3.5	ODYSSEY	401	402	403	512	512	514	676	677	678	N/R	459	459	457	291
02-94	V6	197	3.2	PASSPORT	401	402	403	512	512	514	676	677	678	N/R	459	459	457	291
96-94	L4	160	2.6	PASSPORT	401	402	403	512	512	514	676	677	678	N/R	459	459	457	291
05-02	L4	144	2.4	CRV	401	402	403	512	512	514	676	677	678	N/R	459	459	457	291
98	L4	141	2.3	ODYSSEY	401	402	403	512	512	514	676	677	678	N/R	459	459	457	291
97-95	L4	135	2.2	ODYSSEY	401	402	403	512	512	514	676	677	678	N/R	459	459	457	291
01-97	L4	122	2.0	CR-V	401	402	403	512	512	514	676	677	678	N/R	459	459	457	291
<b>INTERNATIONAL</b>																		
75-74	V8	392	6.4	ALL MODELS	403	404	405	512	514	516	677	678	679	N/R	459	457	1040	291
80-71	V8	345	5.6	ALL MODELS	403	404	405	512	514	516	677	678	679	N/R	459	457	1040	291
80-69	V8	304	5.0	ALL MODELS	403	404	405	512	514	516	677	678	679	N/R	459	457	1040	291
70-68	V8	266	4.4	ALL MODELS	403	404	405	512	514	516	677	678	679	N/R	459	457	1040	291
70-69	L6	265	4.3	ALL MODELS	403	404	405	512	514	516	677	678	679	N/R	459	457	1040	291
75-72	L6	258	4.2	ALL MODELS	403	404	405	512	514	516	677	678	679	N/R	459	457	1040	291
70-68	L6	241	3.9	ALL MODELS	403	404	405	512	514	516	677	678	679	N/R	459	457	1040	291
68-63	L6	232	3.8	ALL MODELS	403	403	404	512	512	514	676	677	678	N/R	459	457	1040	291
80-68	L4	196	3.2	ALL MODELS	403	403	404	512	512	514	676	677	678	N/R	459	457	1040	291
71-61	L4	152	2.5	ALL MODELS	403	403	404	512	512	514	676	677	678	N/R	459	457	1040	291
<b>ISUZU CARS</b>																		
89-88	L4	141	2.3	IMPULSE	401	402	403	512	512	514	676	677	678	N/R	459	457	457	291 (9)
89-85	L4	123	2.0	IMPULSE	401	402	403	512	512	514	676	677	678	N/R	459	457	457	291 (9)
86-83	L4	117	1.9	IMPULSE	401	402	403	512	512	514	676	677	678	N/R	459	457	457	291 (9)
92	L4	111	1.8	IMPULSE	401	402	403	512	512	514	676	677	678	N/R	459	457	457	291 (9)
92	L4	111	1.8	STYLUS	401	402	403	512	512	514	676	677	678	N/R	459	457	457	291 (9)
85-81	L4	111	1.8	I-MARK	401	402	403	512	512	514	676	677	678	N/R	459	457	457	291 (9)
84-81	L4	111	1.8	I-MARK DIESEL	401	402	403	512	512	514	676	677	678	N/R	-	-	-	-
93-91	L4	98	1.6	STYLUS	401	402	403	512	512	514	676	677	678	N/R	459	457	457	291 (9)
92-90	L4	98	1.6	IMPULSE	401	402	403	512	512	514	676	677	678	N/R	459	457	457	291 (9)
89	L4	98	1.6	I-MARK	401	402	403	512	512	514	676	677	678	N/R	459	457	457	291 (9)
89-85	L4	92	1.5	I-MARK	401	402	403	512	512	514	676	677	678	N/R	459	457	457	291 (9)
<b>ISUZU TRUCKS</b>																		
07-03	V8	323	5.3	ASCENDER	403	404	405	512	514	516	677	678	679	397	-	-	-	-
07-03	L6	258	4.2	ASCENDER	403	404	405	512	514	516	677	678	679	397	-	-	-	-
00-97	V6	262	4.3	HOMBRE	401	402	403	512	512	514	676	677	678	390	459	457	1040	291
02-98	V6	215	3.5	TROOPER	401	402	403	512	512	514	676	677	678	N/R	459	459	457	291
04-02	V6	215	3.5	AXIOM	401	402	403	512	512	514	676	677	678	N/R	459	459	457	291
01-99	V6	215	3.5	VEHICROSS	401	402	403	512	512	514	676	677	678	N/R	459	459	457	291
00-98	V6	196	3.2	AMIGO	401	402	403	512	512	514	676	677	678	N/R	459	459	457	291
03-01	V6	196	3.2	RODEO SPORT	401	402	403	512	512	514	676	677	678	N/R	459	459	457	291

(1) Remote filter mount kit is optional unless otherwise noted.  
 (9) Some OEM filters will not seal on the oil filter adapter, Use Fram filter number PH3950 or equivalent.

COOLERS

# TRANSMISSION/ENGINE OIL COOLERS

## Application Guide

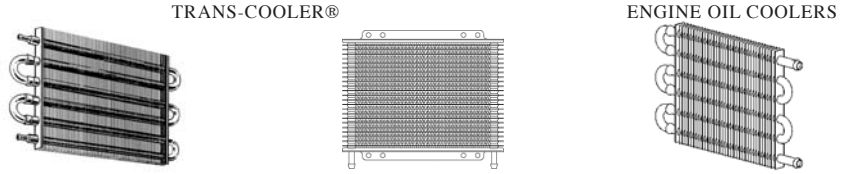

ULTRA-COOL® HIGH PERFORMANCE RAPID-COOL®

YEAR	TYPE	CID	ENGINE LITERS (VIN)	APPLICATION	ULTRA-COOL®			HIGH PERFORMANCE			RAPID-COOL®			REQUIRED TRANS FITTING KIT		REMOTE ENGINE KIT (1)		
					LIGHT DUTY	MEDIUM DUTY	HEAVY DUTY	LIGHT DUTY	MEDIUM DUTY	HEAVY DUTY	LIGHT DUTY	MEDIUM DUTY	HEAVY DUTY	COOL NOTE	LIGHT DUTY	MEDIUM DUTY	HEAVY DUTY	
<b>ISUZU TRUCKS (Cont'd)</b>																		
04-91	V6	196	3.2	RODEO	401	402	403	512	512	514	676	677	678	N/R	459	459	457	291
97-92	V6	196	3.2	TROOPER, S, RS, LTD, LS	401	402	403	512	512	514	676	677	678	N/R	459	459	457	291
94-91	V6	190	3.1	PICKUP	401	402	403	512	512	514	676	677	678	N/R	459	459	457	291
92-91	V6	190	3.1	RODEO	401	402	403	512	512	514	676	677	678	N/R	459	459	457	291
91-89	V6	172	2.8	TROOPER	401	402	403	512	512	514	676	677	678	N/R	459	459	457	291
97-91	L4	160	2.6	RODEO	401	402	403	512	512	514	676	677	678	N/R	459	459	457	291
95-88	L4	160	2.6	PICKUP	401	402	403	512	512	514	676	677	678	N/R	459	459	457	291
94-89	L4	160	2.6	AMIGO	401	402	403	512	512	514	676	677	678	N/R	459	459	457	291
91-88	L4	160	2.6	TROOPER	401	402	403	512	512	514	676	677	678	N/R	459	459	457	291
99-98	L4	141	2.3	OASIS	401	402	403	512	512	514	676	677	678	N/R	459	459	457	291
95-86	L4	141	2.3	PICKUP	401	402	403	512	512	514	676	677	678	N/R	459	459	457	291
93-89	L4	160	2.3	AMIGO	401	402	403	512	512	514	676	677	678	N/R	459	459	457	291
87-86	L4	141	2.3	TROOPER	401	402	403	512	512	514	676	677	678	N/R	459	459	457	291
03-98	L4	135	2.2	RODEO, RODEO SPORT	401	402	403	512	512	514	676	677	678	N/R	459	459	457	291
00-96	L4	135	2.2	HOMBRE	401	402	403	512	512	514	676	677	678	390	459	457	1040	291
00-98	L4	135	2.2	AMIGO	401	402	403	512	512	514	676	677	678	N/R	459	459	457	291
97-96	L4	135	2.2	OASIS	401	402	403	512	512	514	676	677	678	N/R	459	459	457	291
87-81	L4	135	2.2	PICKUP DIESEL	401	402	403	512	512	514	676	677	678	N/R	459	459	457	291
03-98	L4	135	2.2	RODEO, RODEO SPORT	401	402	403	512	512	514	676	677	678	N/R	459	459	457	291
87-84	L4	135	2.2	TROOPER DIESEL	401	402	403	512	512	514	676	677	678	N/R	-	-	-	-
87-81	L4	116	1.9	PICKUP	401	402	403	512	512	514	676	677	678	N/R	459	459	457	291
85-84	L4	117	1.9	PICKUP	401	402	403	512	512	514	676	677	678	N/R	459	459	457	291
82-81	L4	110	1.8	TROOPER	401	402	403	512	512	514	676	677	678	N/R	459	459	457	291
<b>JEEP</b>																		
78-74	V8	401	6.6	ALL MODELS	403	404	405	512	514	516	677	678	679	N/R	459	457	1040	291
98	V8	360	5.9	GRAND CHEROKEE	403	404	405	512	514	516	677	678	679	N/R	459	457	1040	291
90-87	V8	360	5.9	ALL MODELS	403	404	405	512	514	516	677	678	679	N/R	459	457	1040	291
86-72	V8	360	5.9	ALL MODELS	403	404	405	512	514	516	677	678	679	N/R	459	457	1040	291
07-05	V8	350	5.7	GRAND CHEROKEE, HEMI ENGINE, COMMANDER	403	404	405	512	514	516	677	678	679	N/R	459	457	1040	291
71-69	V8	350	5.7	ALL MODELS	403	404	405	512	514	516	677	678	679	N/R	459	457	1040	291
68-65	V8	327	5.4	ALL MODELS	403	404	405	512	514	516	677	678	679	N/R	459	457	1040	291
98-93	V8	318	5.2	ALL MODELS	403	404	405	512	514	516	677	678	679	392	459	457	1040	291
90-87	V8	318	5.2	ALL MODELS	403	404	405	512	514	516	677	678	679	392	459	457	-	291
86-65	V8	318	5.2	ALL MODELS	403	404	405	512	514	516	677	678	679	390	459	457	1040	291
81-72	V8	304	5.0	CHEROKEE	403	404	405	512	514	516	677	678	679	N/R	459	457	1040	291
07-99	V8	285	4.7	GRAND CHEROKEE, COMMANDER	403	404	405	512	514	516	677	678	679	N/R	459	457	1040	291
90-87	L6	258	4.2	ALL MODELS	401	402	403	512	512	514	676	677	678	391 or 392	459	457	-	291
86-72	L6	258	4.2	CHEROKEE	401	402	403	512	512	514	676	677	678	N/R	459	457	1040	291
07-91	L6	242	4.0	ALL MODELS	401	402	403	512	512	514	676	677	678	391 or 392	459	457	1040	291
90-87	L6	242	4.0	ALL MODELS	401	402	403	512	512	514	676	677	678	391 or 392	459	457	-	291
78-62	L6	232	3.8	ALL MODELS	401	402	403	512	512	514	676	677	678	N/R	459	457	1040	291
07-02	V6	226	3.7	LIBERTY, GRAND CHEROKEE, COMMANDER	401	402	403	512	512	514	676	677	678	N/R	459	457	1040	291
71-62	L6	225	3.7	ALL MODELS	401	402	403	512	512	514	676	677	678	N/R	459	457	1040	291
2007	V6	182	3.0	GRAND CHEROKEE	401	402	403	512	512	514	676	677	678	390	459	457	1040	291
06-05	L4	173	2.8	LIBERTY	401	402	403	512	512	514	676	677	678	390	459	457	1040	291

(1) Remote filter mount kit is optional unless otherwise noted.

# TRANSMISSION/ENGINE OIL COOLERS

## Application Guide

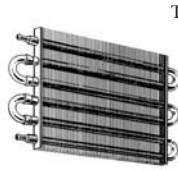

TRANS-COOLER®

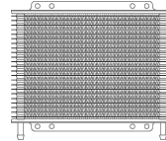

HIGH PERFORMANCE

RAPID-COOL®

ENGINE OIL COOLERS

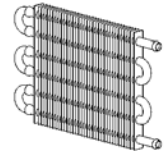

YEAR	TYPE	CID	ENGINE LITERS (VIN)	APPLICATION	ULTRA-COOL®			HIGH PERFORMANCE			RAPID-COOL®			REQUIRED TRANS FITTING KIT		REMOTE ENGINE KIT (1)		
					LIGHT DUTY	MEDIUM DUTY	HEAVY DUTY	LIGHT DUTY	MEDIUM DUTY	HEAVY DUTY	LIGHT DUTY	MEDIUM DUTY	HEAVY DUTY	COOL NOTE	LIGHT DUTY	MEDIUM DUTY	HEAVY DUTY	
<b>JEEP (Cont'd)</b>																		
86-84	V6	173	2.8	ALL MODELS	401	402	403	512	512	514	676	677	678	390	459	457	1040	291
02-94	L4	151	2.5	ALL MODELS	401	402	403	512	512	514	676	677	678	391 or 392	459	457	1040	291 (2)
93-91	L4	151	2.5	ALL MODELS	401	402	403	512	512	514	676	677	678	391 or 392	459	457	1040	291
90-87	L4	151	2.5	ALL MODELS	401	402	403	512	512	514	676	677	678	391 or 392	459	457	—	291
86-80	L4	151	2.5	ALL MODELS	401	402	403	512	512	514	676	677	678	390	459	457	457	291 (2)
07-03	L4	148	2.4	WRANGLER, LIBERTY	401	402	403	512	512	514	676	677	678	N/R	459	457	457	291 (2)
71-60	L4	134	2.2	ALL MODELS	401	402	403	512	512	514	676	677	678	N/R	459	457	457	291 (2)
87-85	L4	121	2.1	ALL TURBO DIESELS	401	402	403	512	512	514	676	677	678	390	459	457	457	291
<b>LINCOLN CARS</b>																		
78-68	V8	460	7.5	CONTINENTAL, MARK III, IV, V	403	404	405	512	514	516	677	678	679	N/R	459	457	1040	291
79-78	V8	400	6.6	CONTINENTAL, MARK V	403	404	405	512	514	516	677	678	679	N/R	459	457	1040	291
80	V8	351	5.8	CONTINENTAL, MARK IV	403	404	405	512	514	516	677	678	679	N/R	459	457	1040	291
77	V8	351	5.8	VERSAILLES	403	404	405	512	514	516	677	678	679	N/R	459	457	1040	291
92-77	V8	302	5.0	ALL MODELS	401	402	403	512	512	514	676	677	678	77017	459	457	1040	291
07-91	V8	281	4.6	ALL CAR MODELS	401	402	403	512	512	514	676	677	678	252 or 394 (4)	—	—	—	—
06-00	V8	242	3.9	LS	401	402	403	512	512	514	676	677	678					
94-88	V6	232	3.8	CONTINENTAL	401	402	403	512	512	514	676	677	678	252 or 394 (4)	459	457	1040	291
2007	V6	213	3.5	MKZ	—	—	—	—	—	—	—	—	—	—	—	—	—	—
05-00	V6	182	3.0	LS	401	402	403	512	512	514	676	677	678	N/R	—	—	—	—
2006	V6	182	3.0	ZEPHYR	401	402	403	512	512	514	676	677	678	N/R	—	—	—	—
<b>LINCOLN TRUCKS &amp; SUV's</b>																		
07-98	V8	330	5.4	NAVIGATOR	403	404	405	512	514	516	677	678	679	395	—	—	—	—
07-06	V8	330	5.4	MARK LT	403	404	405	512	514	516	677	678	679	395	—	—	—	—
03-02	V8	330	5.4	BLACKWOOD	403	404	405	512	514	516	677	678	679	395	—	—	—	—
05-03	V8	281	4.6	AVIATOR	—	—	—	—	—	—	—	—	—	—	—	—	—	—
2007	V8	213	3.5	MKX	—	—	—	—	—	—	—	—	—	—	—	—	—	—
<b>MAZDA TRUCKS</b>																		
07-94	V6	246	4.0	B4000	403	404	404	512	514	514	677	678	679	395 (19)	459	457	1040	291 (2)
95-91	V6	246	4.0	NAVAJO	403	404	404	512	514	514	677	678	679	395 (19)	459	457	1040	291 (2)
07-94	V6	182	3.0	B3000	403	404	404	512	514	514	677	678	679	395 (19)	459	457	1040	291 (2)
06-01	V6	184	3.0	TRIBUTE	401	402	403	512	512	514	677	678	679	N/R	459	457	457	291 (9)
93-87	L4	160	2.6	B2600	401	402	403	512	512	514	676	677	678	N/R	459	457	457	291
01-98	L4	154	2.5	B2500	401	402	403	512	512	514	676	677	678	395 (19)	459	457	457	291
07-01	L4	141	2.3	B2300, TRIBUTE	401	402	403	512	512	514	676	677	678	395	459	457	457	291
97-94	L4	141	2.3	B2300	401	402	403	512	512	514	676	677	678	252	459	457	457	291
93-87	L4	135	2.2	B2200	401	402	403	512	512	514	676	677	678	252	459	457	457	291
84-82	L4	135	2.2	B2200 DIESEL	401	402	403	512	512	514	676	677	678	N/R	—	—	—	—
04-01	L4	122	2.0	TRIBUTE	401	402	403	512	512	514	677	678	679	N/R	459	457	457	291 (9)
86-79	L4	122	2.0	B2000	401	402	403	512	512	514	676	677	678	252	459	457	457	291
<b>MAZDA CARS</b>																		
2007	V6	213	3.5	CX-9	—	—	—	—	—	—	—	—	—	—	—	—	—	—
05-03	V6	184	3.0	MPV	401	402	403	512	512	514	677	678	679	N/R	459	457	457	291 (9)
98-89	V6	184	3.0	MPV	401	402	403	512	512	514	677	678	679	N/R	459	457	457	291 (9)
95-88	V6	184	3.0	929	401	402	403	512	512	514	677	678	679	N/R	459	457	457	291 (9)

(1) Remote filter mount kit is optional unless otherwise noted.

(4) Use kit #252 with snap-in (duckbill) type trans line fittings. Use kit #394 with 1/2"-20 partial thread fittings.

(9) Some OEM filters will not seal on the oil filter adapter. Use Fram filter number PH3950 or equivalent.

(19) Use kit #395 on vehicles with 5/8"-18 thread on trans line fitting. Use kit #394 with 1/2"-20 thread fittings.

(2) Check for 2" oil filter clearance, some vehicles require remote kit #291.

# TRANSMISSION/ENGINE OIL COOLERS

## Application Guide

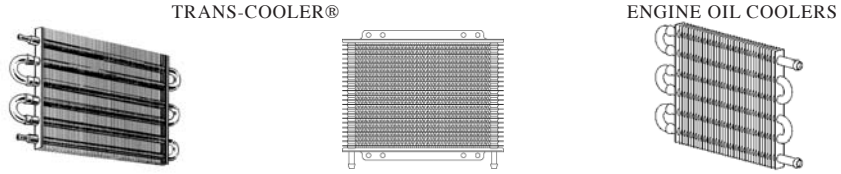

ULTRA-COOL® HIGH PERFORMANCE RAPID-COOL®

YEAR	TYPE	CID	ENGINE LITERS (VIN)	APPLICATION	ULTRA-COOL®			HIGH PERFORMANCE			RAPID-COOL®			REQUIRED TRANS		REMOTE ENGINE			
					LIGHT DUTY	MEDIUM DUTY	HEAVY DUTY	LIGHT DUTY	MEDIUM DUTY	HEAVY DUTY	LIGHT DUTY	MEDIUM DUTY	HEAVY DUTY	FITTING KIT	COOLR NOTE	LIGHT DUTY	MEDIUM DUTY	HEAVY DUTY	KIT (1)
<b>MAZDA CARS (Cont'd)</b>																			
94-89	L4	160	2.6	MPV	401	402	403	512	512	514	677	678	679	N/R		459	457	457	291 (9)
02-95	V6	154	2.5	MILLENNIA	401	402	403	512	512	514	677	678	679	N/R		459	457	457	291 (9)
02-00	V6	154	2.5	MPV	401	402	403	512	512	514	677	678	679	N/R		459	457	457	291 (9)
02-93	V6	154	2.5	626	401	402	403	512	512	514	677	678	679	N/R		459	457	457	291 (9)
97-93	V6	154	2.5	MX-6	401	402	403	512	512	514	677	678	679	N/R		459	457	457	291 (9)
2007	L4	141	2.3	CX-7	401	402	403	512	512	514	676	677	678	N/R		459	457	457	291 (9)
02-95	V6	141	2.3	MILLENNIA	401	402	403	512	512	514	676	677	678	N/R		459	457	457	291 (9)
93-88	L4	135	2.2	626	401	402	403	512	512	514	676	677	678	N/R		459	457	457	291 (9)
92-88	L4	135	2.2	MX-6	401	402	403	512	512	514	676	677	678	N/R		459	457	457	291 (9)
07-06	L4	123	2.0	MX-5 MIATA	401	402	403	512	512	514	676	677	678	N/R		459	457	457	291 (9)
03-01	L4	123	2.0	PROTÉGÉ, PROTÉGÉ 5	401	402	403	512	512	514	676	677	678	N/R		459	457	457	291 (9)
01-93	L4	123	2.0	626	401	402	403	512	512	514	676	677	678	N/R		459	457	457	291 (9)
01	L4	123	2.0	TRIBUTE	401	402	403	512	512	514	676	677	678	N/R		459	457	457	291 (9)
97	L4	123	2.0	MX-6	401	402	403	512	512	514	676	677	678	N/R		459	457	457	291 (9)
87-79	L4	123	2.0	626	401	402	403	512	512	514	676	677	678	N/R		459	457	457	291 (9)
04-90	L4	111	1.8	MIATA	401	402	403	512	512	514	676	677	678	N/R		459	457	457	291 (9)
00-90	L4	111	1.8	PROTEGE	401	402	403	512	512	514	676	677	678	N/R		459	457	457	291 (9)
95-92	V6	111	1.8	MX-3	401	402	403	512	512	514	676	677	678	N/R		459	457	457	291 (9)
91-90	L4	111	1.8	323	401	402	403	512	512	514	676	677	678	N/R		459	457	457	291 (9)
01-99	L4	98	1.6	PROTEGE	401	402	403	512	512	514	676	677	678	N/R		459	457	457	291 (9)
95-92	L4	98	1.6	MX-3	401	402	403	512	512	514	676	677	678	N/R		459	457	457	291 (9)
95-86	L4	98	1.6	323	401	402	403	512	512	514	676	677	678	N/R		459	457	457	291 (9)
98-95	L4	92	1.5	PROTEGE	401	402	403	512	512	514	676	677	678	N/R		459	457	457	291 (9)
86-81	L4	92	1.5	GLC	401	402	403	512	512	514	676	677	678	N/R		459	457	457	291 (9)
94-79	R2	80	1.3	RX-7	401	402	403	512	512	514	676	677	678	N/R		459	457	457	291
07-05	R2		1.3	RX-8	-	-	-	-	-	-	-	-	-	-		-	-	-	-
<b>MERCURY CARS</b>																			
78-72	V8	460	7.5	ALL MODELS	403	404	405	512	514	516	677	678	679	N/R		459	1040	1040	291
73-69	V8	429	7.0	ALL MODELS	403	404	405	512	514	516	677	678	679	N/R		459	1040	1040	291
70-66	V8	428	7.0	ALL MODELS	403	404	405	512	514	516	677	678	679	N/R		459	1040	1040	291
68-65	V8	427	7.0	ALL MODELS	403	404	405	512	514	516	677	678	679	N/R		459	1040	1040	291
78-71	V8	400	6.6	ALL MODELS	403	404	405	512	514	516	677	678	679	N/R		459	1040	1040	291
70-61	V8	390	6.4	ALL MODELS	403	404	405	512	514	516	677	678	679	N/R		459	1040	1040	291
89-84	V8	351	5.8	ALL MODELS	401	402	403	512	512	514	676	677	678	252 or 394 (4)		459	457	1040	291 (2)
82-69	V8	351	5.8	ALL MODELS	401	402	403	512	512	514	676	677	678	N/R		459	457	1040	291 (2)
93-83	V8	302	5.0	ALL MODELS	401	402	403	512	512	514	676	677	678	252 or 394 (4)		459	457	1040	291 (2)
82-68	V8	302	5.0	ALL MODELS	401	402	403	512	512	514	676	677	678	N/R		459	457	1040	291 (2)
68-64	V8	289	4.7	ALL MODELS	401	402	403	512	512	514	676	677	678	N/R		459	457	1040	291 (2)
07-92	V8	281	4.6	ALL MODELS	401	402	403	512	512	514	676	677	678	252 or 394 (4)		-	-	-	-
82-80	V8	255	4.2	ALL MODELS	401	402	403	512	512	514	676	677	678	N/R		459	457	1040	291 (2)
80-69	L6	250	4.1	ALL MODELS	401	402	403	512	512	514	676	677	678	N/R		459	457	1040	291
97-82	V6	232	3.8	ALL MODELS	401	402	403	512	512	514	676	677	678	252 or 394 (4)		459	457	1040	291
83-63	L6	200	3.3	ALL MODELS	401	402	403	512	512	514	676	677	678	N/R		459	457	1040	291
05-86	V6	182	3.0	SABLE, TOPAZ	401	402	403	512	512	514	676	677	678	252 or 394 (4)		459	459	457	291 (2)
79-74	V6	171	2.8	CAPRI, BOBCAT	401	402	403	512	512	514	676	677	678	N/R		459	459	457	291 (2)
72-60	L6	170	2.8	ALL MODELS	401	402	403	512	512	514	676	677	678	N/R		459	459	457	291 (2)
02-93	V6	152	2.5	MYSTIQUE, COUGAR	401	402	403	512	512	514	676	677	678	390		459	457	457	- (18)

(1) Remote filter mount kit is optional unless otherwise noted.

(4) Use kit #252 with snap-in (duckbill) type trans line fittings. Use kit #394 with 1/2"-20 partial thread fittings.

(9) Some OEM filters will not seal on the oil filter adapter, Use Fram filter number PH3950 or equivalent.

(2) Check for 2" oil filter clearance, some vehicles require remote kit #291.

(18) No remote oil filter applications for engines with 22MM oil filter thread.

# TRANSMISSION/ENGINE OIL COOLERS

## Application Guide

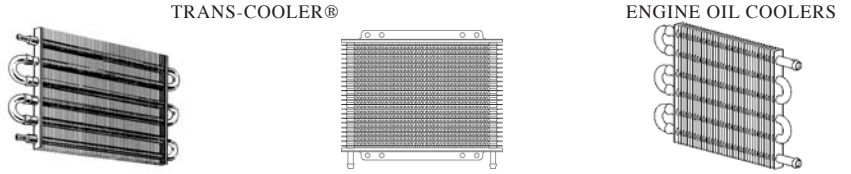

YEAR	TYPE	CID	ENGINE LITERS (VIN)	APPLICATION	ULTRA-COOL®			HIGH PERFORMANCE			RAPID-COOL®			REQUIRED TRANS FITTING KIT		TRANS COOL NOTE			REMOTE ENGINE KIT (1)		COOLER NOTE
					LIGHT DUTY	MEDIUM DUTY	HEAVY DUTY	LIGHT DUTY	MEDIUM DUTY	HEAVY DUTY	LIGHT DUTY	MEDIUM DUTY	HEAVY DUTY	LIGHT DUTY	MEDIUM DUTY	HEAVY DUTY	(1)	(2)			
<b>MERCURY CARS (Cont'd)</b>																					
86	L4	153	2.5	SABLE	401	402	403	512	512	514	676	677	678	252 or 394 (4)	459	459	457	291	(2)		
94-83	L4	140	2.3	ALL MODELS	401	402	403	512	512	514	676	677	678	252 or 394 (4)	459	459	457	291	(2)		
82-74	L4	140	2.3	ALL MODELS	401	402	403	512	512	514	676	677	678	N/R	459	459	457	291	(2)		
02-95	L4	122	2.0	MYSTIQUE, COUGAR, TRACER	401	402	403	512	512	514	676	677	678	390	459	457	457	291			
87-84	L4	122	2.0	DIESEL, LYNX & TOPAZ	401	402	403	512	512	514	676	677	678	N/R	459	457	457	291			
74-71	L4	122	2.0	CAPRI	401	402	403	512	512	514	676	677	678	390	459	457	457	291			
96-85	L4	116	1.9	TRACER, LYNX	401	402	403	512	512	514	676	677	678	N/R	459	459	457	291			
96-91	L4	110	1.8	TRACER	401	402	403	512	512	514	676	677	678	N/R	459	459	457	291			
94-71	L4	98	1.6	ALL MODELS	401	402	403	512	512	514	676	677	678	N/R	459	459	457	291			
<b>MERCURY SUV's AND VANS</b>																					
01-97	V8	302	5.0	MOUNTAINEER	403	404	405	512	514	516	677	678	679	395	459	457	1040	-	(18)		
07-02	V8	281	4.6	MOUNTAINEER	-	-	-	-	-	-	-	-	-	-	-	-	-	-	-		
07-98	V6	245	4.0	MOUNTAINEER	403	404	404	512	514	514	677	678	679	395	459	457	1040	291	(2)		
02-99	V6	202	3.3	VILLAGER	403	404	404	512	514	514	677	678	679	N/R	459	459	457	291			
07-05	V6	183	3.0	MARINER	-	-	-	-	-	-	-	-	-	-	-	-	-	-	-		
98-93	V6	183	3.0	VILLAGER	403	404	404	512	514	514	677	678	679	N/R	-	-	-	-			
07-05	L4	140	2.3	MARINER	-	-	-	-	-	-	-	-	-	-	-	-	-	-	-		
<b>MITSUBISHI CARS</b>																					
07-06	V6	230	3.8	ECLIPSE	401	402	403	512	512	514	676	677	678	N/R	459	457	457	291	(9),(2)		
04-97	V6	215	3.5	DIAMANTE	401	402	403	512	512	514	676	677	678	N/R	459	457	457	291	(9),(2)		
04-00	V6	181	3.0	ECLIPSE	401	402	403	512	512	514	676	677	678	N/R	459	457	457	291	(9),(2)		
03-99	V6	181	3.0	GALANT	401	402	403	512	512	514	676	677	678	N/R	459	457	457	291	(9),(2)		
99-91	V6	181	3.0	3000GT	401	402	403	512	512	514	676	677	678	N/R	459	457	457	291	(9),(2)		
96-92	V6	181	3.0	DIAMANTE	401	402	403	512	512	514	676	677	678	N/R	459	457	457	291	(9),(2)		
90-88	V6	181	3.0	SIGMA	401	402	403	512	512	514	676	677	678	N/R	459	457	457	291	(9),(2)		
89-83	L4	156	2.6	STARION	401	402	403	512	512	514	676	677	678	N/R	459	457	457	291	(9),(2)		
07-96	L4	147	2.4	ECLIPSE	401	402	403	512	512	514	676	677	678	N/R	459	457	457	291	(9),(2)		
04-85	L4	147	2.4	GALANT	401	402	403	512	512	514	676	677	678	N/R	459	457	457	291	(9),(2)		
95-92	L4	147	2.4	EXPO	401	402	403	512	512	514	676	677	678	N/R	459	457	457	291	(9),(2)		
94-93	L4	147	2.4	EXPO LRV	401	402	403	512	512	514	676	677	678	N/R	459	457	457	291	(9),(2)		
99-90	L4	122	2.0	ECLIPSE	401	402	403	512	512	514	676	677	678	N/R	459	457	457	291	(9)		
93-89	L4	122	2.0	GALANT	401	402	403	512	512	514	676	677	678	N/R	459	457	457	291	(9)		
88-84	L4	122	2.0	CORDIA	401	402	403	512	512	514	676	677	678	N/R	459	457	457	291	(9)		
88-84	L4	122	2.0	TREDIA	401	402	403	512	512	514	676	677	678	N/R	459	457	457	291	(9)		
94-92	L4	112	1.8	EXPO LRV	401	402	403	512	512	514	676	677	678	N/R	459	457	457	291	(9)		
94-90	L4	112	1.8	ECLIPSE	401	402	403	512	512	514	676	677	678	N/R	459	457	457	291	(9)		
02-93	L4	112	1.8	MIRAGE	401	402	403	512	512	514	676	677	678	N/R	459	457	457	291	(9)		
88-83	L4	111	1.8	CORDIA	401	402	403	512	512	514	676	677	678	N/R	459	457	457	291	(9)		
88-83	L4	111	1.8	TREDIA	401	402	403	512	512	514	676	677	678	N/R	459	457	457	291	(9)		
92-85	L4	98	1.6	MIRAGE	401	402	403	512	512	514	676	677	678	N/R	459	457	457	291	(9)		
01-85	L4	90	1.5	MIRAGE	401	402	403	512	512	514	676	677	678	N/R	459	457	457	291	(9)		
93-87	L4	92	1.5	PRECIS	401	402	403	512	512	514	676	677	678	N/R	459	457	457	291	(9)		
<b>MITSUBISHI TRUCKS, VANS AND SUVs</b>																					
07-06	V8	285	4.7	RAIDER	401	402	403	512	512	514	676	677	678	N/R	459	457	457	291	(9)		
07-05	V6	230	3.8	ENDEAVOR	401	402	403	512	512	514	676	677	678	N/R	459	457	457	291	(9)		
06-05	V6	230	3.8	MONTERO	401	402	403	512	512	514	676	677	678	N/R	459	457	457	291	(9)		

(1) Remote filter mount kit is optional unless otherwise noted.

(4) Use kit #252 with snap-in (duckbill) type trans line fittings. Use kit #394 with 1/2"-20 partial thread fittings.

(9) Some OEM filters will not seal on the oil filter adapter, Use Fram filter number PH3950 or equivalent.

(2) Check for 2" oil filter clearance, some vehicles require remote kit #291.

(18) No remote oil filter applications for engines with 22MM oil filter thread.

# TRANSMISSION/ENGINE OIL COOLERS

## Application Guide

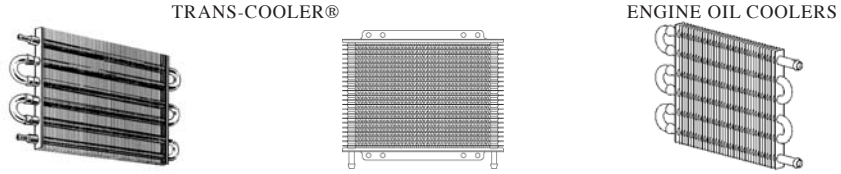

ULTRA-COOL® HIGH PERFORMANCE RAPID-COOL®

YEAR	TYPE	CID	ENGINE LITERS (VIN)	APPLICATION	ULTRA-COOL®			HIGH PERFORMANCE			RAPID-COOL®			REQUIRED TRANS FITTING KIT		REMOTE ENGINE KIT (1)			ENGINE COOLER NOTE
					LIGHT DUTY	MEDIUM DUTY	HEAVY DUTY	LIGHT DUTY	MEDIUM DUTY	HEAVY DUTY	LIGHT DUTY	MEDIUM DUTY	HEAVY DUTY	COOLR NOTE	LIGHT DUTY	MEDIUM DUTY	HEAVY DUTY		
<b>MITSUBISHI TRUCKS, VANS AND SUVS (Cont'd)</b>																			
07-06	V6	226	3.7	RAIDER	401	402	403	512	512	514	676	677	678	N/R		459	457	457	291 (9)
04-99	V6	215	3.5	MONTERO SPORT	401	402	403	512	512	514	676	677	678	N/R		459	457	457	291 (9)
02-94	V6	215	3.5	MONTERO	401	402	403	512	512	514	676	677	678	N/R		459	457	457	291 (9)
03-97	V6	181	3.0	MONTERO SPORT	401	402	403	512	512	514	676	677	678	N/R		459	457	457	291 (9)
96-89	V6	181	3.0	MONTERO	401	402	403	512	512	514	676	677	678	N/R		459	457	457	291 (9)
94-90	V6	181	3.0	MIGHTY MAX	401	402	403	512	512	514	676	677	678	N/R		459	457	457	291 (9)
2007	V6	182	3.0	OUTLANDER	401	402	403	512	512	514	676	677	678	N/R		459	457	457	291 (9)
89-83	L4	156	2.6	MONTERO	401	402	403	512	512	514	676	677	678	N/R		459	457	457	291 (9)
89-83	L4	156	2.6	MIGHTY MAX	401	402	403	512	512	514	676	677	678	N/R		459	457	457	291 (9)
99-97	L4	147	2.4	MONTERO SPORT	401	402	403	512	512	514	676	677	678	N/R		459	457	457	291 (9)
06-03	L4	147	2.4	OUTLANDER	401	402	403	512	512	514	676	677	678	N/R		459	457	457	291 (9)
90-87	L4	147	2.4	VAN	401	402	403	512	512	514	676	677	678	N/R		459	457	457	291 (9)
96-90	L4	147	2.4	MIGHTY MAX	401	402	403	512	512	514	676	677	678	N/R		459	457	457	291 (9)
85-83	L4	143	2.3	MIGHTY MAX	401	402	403	512	512	514	676	677	678	N/R		459	457	457	291 (9)
89-83	L4	122	2.0	MIGHTY MAX	401	402	403	512	512	514	676	677	678	N/R		459	457	457	291 (9)
<b>NISSAN CARS</b>																			
07-98	V6	215	3.5	ALTIMA	401	402	403	512	512	514	676	677	678	N/R		459	457	1040	291
07-02	V6	215	3.5	MAXIMA	401	402	403	512	512	514	676	677	678	N/R		459	457	1040	291
01-85	V6	184	3.0	MAXIMA	401	402	403	512	512	514	676	677	678	N/R		-	-	-	-
96-84	V6	184	3.0	300ZX	401	402	403	512	512	514	676	677	678	N/R		-	-	-	-
88-87	V6	184	3.0	200SX	401	402	403	512	512	514	676	677	678	N/R		-	-	-	-
83-78	L6	172	2.8	280ZX	401	402	403	512	512	514	676	677	678	N/R		459	457	1040	291
78-75	L6	172	2.8	280Z	401	402	403	512	512	514	676	677	678	N/R		459	457	1040	291
74	L6	160	2.6	260Z	401	402	403	512	512	514	676	677	678	N/R		459	457	1040	291
07-98	L4	154	2.5	ALTIMA, SENTRA	401	402	403	512	512	514	676	677	678	N/R		459	457	1040	291
01-93	L4	147	2.4	ALTIMA	401	402	403	512	512	514	676	677	678	N/R		459	457	1040	291
98-89	L4	147	2.4	240SX	401	402	403	512	512	514	676	677	678	N/R		459	457	1040	291
95-90	L4	147	2.4	AXXESS	401	402	403	512	512	514	676	677	678	N/R		459	457	1040	291
92-90	L4	147	2.4	STANZA	401	402	403	512	512	514	676	677	678	N/R		459	457	1040	291
84-82	L6	147	2.4	MAXIMA	401	402	403	512	512	514	676	677	678	N/R		459	457	1040	291
81-77	L6	147	2.4	810	401	402	403	512	512	514	676	677	678	N/R		459	457	1040	291
73-70	L6	147	2.4	240Z	401	402	403	512	512	514	676	677	678	N/R		459	457	1040	291
83-82	L4	135	2.2	200SX	401	402	403	512	512	514	676	677	678	N/R		459	457	1040	291
07-91	L4	123	2.0	SENTRA	401	402	403	512	512	514	676	677	678	N/R		459	457	1040	291
98-95	L4	123	2.0	200SX	401	402	403	512	512	514	676	677	678	N/R		459	457	1040	291
93-91	L4	123	2.0	NX	401	402	403	512	512	514	676	677	678	N/R		459	457	1040	291
89-82	L4	123	2.0	STANZA	401	402	403	512	512	514	676	677	678	N/R		459	457	1040	291
88-86	L4	122	2.0	MULTI	401	402	403	512	512	514	676	677	678	N/R		459	457	1040	291
88-77	L4	123	2.0	200SX	401	402	403	512	512	514	676	677	678	N/R		459	457	1040	291
07-00	L4	111	1.8	SENTRA	401	402	403	512	512	514	676	677	678	N/R		459	457	1040	291
89-88	L4	111	1.8	PULSAR NX	401	402	403	512	512	514	676	677	678	N/R		459	457	1040	291
87-84	L4	111	1.8	200SX	401	402	403	512	512	514	676	677	678	N/R		459	457	1040	291
87-83	L4	104	1.7	SENTRA	401	402	403	512	512	514	676	677	678	N/R		459	457	1040	291
99-84	L4	98	1.6	SENTRA	401	402	403	512	512	514	676	677	678	N/R		459	457	1040	291
98-95	L4	98	1.6	200SX	401	402	403	512	512	514	676	677	678	N/R		459	457	1040	291
90-83	L4	98	1.6	PULSAR	401	402	403	512	512	514	676	677	678	N/R		459	457	1040	291
90-83	L4	98	1.6	PULSAR NX	401	402	403	512	512	514	676	677	678	N/R		459	457	1040	291

(1) Remote filter mount kit is optional unless otherwise noted.  
 (9) Some OEM filters will not seal on the oil filter adapter, Use Fram filter number PH3950 or equivalent.

# TRANSMISSION/ENGINE OIL COOLERS

## Application Guide

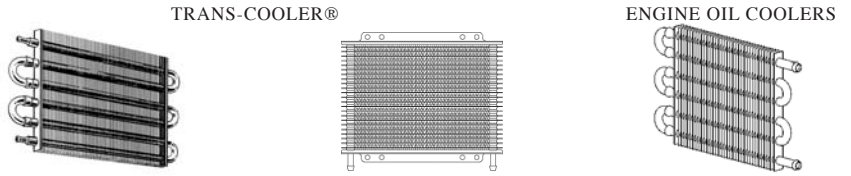

YEAR	TYPE	CID	ENGINE LITERS (VIN)	APPLICATION	ULTRA-COOL®			HIGH PERFORMANCE			RAPID-COOL®			REQUIRED TRANS FITTING KIT		REMOTE ENGINE KIT (1)		
					LIGHT DUTY	MEDIUM DUTY	HEAVY DUTY	LIGHT DUTY	MEDIUM DUTY	HEAVY DUTY	LIGHT DUTY	MEDIUM DUTY	HEAVY DUTY	COOLR NOTE	LIGHT DUTY	MEDIUM DUTY	HEAVY DUTY	
<b>NISSAN CARS (Cont'd)</b>																		
83-82	L4	92	1.5	SENTRA	401	402	403	512	512	514	676	677	678	N/R	459	457	1040	291
82-81	L4	92	1.5	310	401	402	403	512	512	514	676	677	678	N/R	459	457	1040	291
82-80	L4	92	1.5	210	401	402	403	512	512	514	676	677	678	N/R	459	457	1040	291
82-81	L4	85	1.4	310	401	402	403	512	512	514	676	677	678	N/R	459	457	1040	291
82-79	L4	85	1.4	210	401	402	403	512	512	514	676	677	678	N/R	459	457	1040	291
78-76	L4	85	1.4	F10	401	402	403	512	512	514	676	677	678	N/R	459	457	1040	291
78-74	L4	85	1.4	B210	401	402	403	512	512	514	676	677	678	N/R	459	457	1040	291
91-84	L4	75	1.2	MICRA	401	402	403	512	512	514	676	677	678	N/R	459	457	1040	291
82-79	L4	74	1.2	210	401	402	403	512	512	514	676	677	678	N/R	459	457	1040	291
<b>NISSAN TRUCKS, VANS AND SUVS</b>																		
07-04	V8	345	5.6	ARMADA, TITAN	401	402	403	512	512	514	676	677	678	N/R	-	-	-	-
07-05	V6	245	4.0	PATHFINDER, FRONTIER, XTERRA	401	402	403	512	512	514	676	677	678	N/R	-	-	-	-
07-05	V6	215	3.5	MURANO, QUEST	401	402	403	512	512	514	676	677	678	N/R	459	457	457	291
05-01	V6	215	3.5	PATHFINDER	401	402	403	512	512	514	676	677	678	N/R	459	457	457	291
00-96	V6	203	3.3	PATHFINDER	401	402	403	512	512	514	676	677	678	N/R	459	457	457	291
05-00	V6	203	3.3	XTERRA	401	402	403	512	512	514	676	677	678	N/R	-	-	-	-
05-98	V6	203	3.3	QUEST	401	402	403	512	512	514	676	677	678	N/R	-	-	-	-
05-99	V6	203	3.3	FRONTIER	401	402	403	512	512	514	676	677	678	N/R	-	-	-	-
98-93	V6	184	3.0	QUEST	401	402	403	512	512	514	676	677	678	N/R	-	-	-	-
96-94	V6	183	3.0	PICKUP	401	402	403	512	512	514	676	677	678	N/R	-	-	-	-
95-87	V6	183	3.0	PATHFINDER	401	402	403	512	512	514	676	677	678	N/R	-	-	-	-
94-86	V6	183	3.0	D21 PICKUP	401	402	403	512	512	514	676	677	678	N/R	-	-	-	-
86	V6	181	3.0	DIESEL 720 PICKUP	401	402	403	512	512	514	676	677	678	N/R	-	-	-	-
86-83	L4	154	2.5	720 PICKUP	401	402	403	512	512	514	676	677	678	N/R	459	459	457	291
07-05	L4	154	2.5	FRONTIER	401	402	403	512	512	514	676	677	678	N/R	-	-	-	-
07-05	L4	154	2.5	X-TRAIL	401	402	403	512	512	514	676	677	678	N/R	-	-	-	-
05-98	L4	147	2.4	FRONTIER	401	402	403	512	512	514	676	677	678	N/R	459	459	457	291
05-00	L4	147	2.4	XTERRA	401	402	403	512	512	514	676	677	678	N/R	459	459	457	291
97-94	L4	147	2.4	PICKUP	401	402	403	512	512	514	676	677	678	N/R	459	459	457	291
94-86	L4	147	2.4	D21 PICKUP	401	402	403	512	512	514	676	677	678	N/R	459	459	457	291
90-87	L4	147	2.4	VAN	401	402	403	512	512	514	676	677	678	N/R	459	459	457	291
89-87	L4	147	2.4	PATHFINDER	401	402	403	512	512	514	676	677	678	N/R	459	459	457	291
86-83	L4	147	2.4	720 PICKUP	401	402	403	512	512	514	676	677	678	N/R	459	459	457	291
83-81	L4	135	2.2	DIESEL 720 PICKUP	401	402	403	512	512	514	676	677	678	N/R	459	459	457	291
83-81	L4	135	2.2	720 PICKUP	401	402	403	512	512	514	676	677	678	N/R	459	459	457	291
85-80	L4	123	2.0	720 PICKUP	401	402	403	512	512	514	676	677	678	N/R	459	459	457	291
81-78	L4	123	2.0	510	401	402	403	512	512	514	676	677	678	N/R	459	459	457	291
79-75	L4	123	2.0	620 PICKUP	401	402	403	512	512	514	676	677	678	N/R	459	459	457	291
76-75	L4	123	2.0	610	401	402	403	512	512	514	676	677	678	N/R	459	459	457	291
74	L4	111	1.8	710	401	402	403	512	512	514	676	677	678	N/R	459	459	457	291
74	L4	111	1.8	620 PICKUP	401	402	403	512	512	514	676	677	678	N/R	459	459	457	291
73	L4	111	1.8	610	401	402	403	512	512	514	676	677	678	N/R	459	459	457	291
73-72	L4	98	1.6	620 PICKUP	401	402	403	512	512	514	676	677	678	N/R	459	459	457	291
73-68	L4	98	1.6	510	401	402	403	512	512	514	676	677	678	N/R	459	459	457	291
72-70	L4	98	1.6	521 PICKUP	401	402	403	512	512	514	676	677	678	N/R	459	459	457	291
69	L4	79	1.3	521 PICKUP	401	402	403	512	512	514	676	677	678	N/R	459	459	457	291
68-65	L4	79	1.3	520 PICKUP	401	402	403	512	512	514	676	677	678	N/R	459	459	457	291
73-71	L4	74	1.2	1200	401	402	403	512	512	514	676	677	678	N/R	459	459	457	291

(1) Remote filter mount kit is optional unless otherwise noted.

# TRANSMISSION/ENGINE OIL COOLERS

## Application Guide

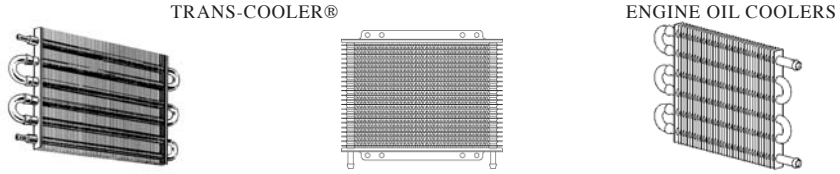

ULTRA-COOL® HIGH PERFORMANCE RAPID-COOL®

ENGINE OIL COOLERS

YEAR	TYPE	CID	ENGINE LITERS (VIN)	APPLICATION	ULTRA-COOL®			HIGH PERFORMANCE			RAPID-COOL®			REQUIRED FITTING KIT	TRANS COOL NOTE	REMOTE ENGINE KIT (1)			ENGINE COOLER NOTE
					LIGHT DUTY	MEDIUM DUTY	HEAVY DUTY	LIGHT DUTY	MEDIUM DUTY	HEAVY DUTY	LIGHT DUTY	MEDIUM DUTY	HEAVY DUTY			LIGHT DUTY	MEDIUM DUTY	HEAVY DUTY	
<b>OLDSMOBILE TRUCKS</b>																			
04-02	L6	258	4.2	BRAVADA	401	402	403	512	512	514	676	677	678	397		-	-	-	-
01-96	V6	262	4.3	BRAVADA	401	402	403	512	512	514	676	677	678	390		459	457	1040	291
95-91	V6	262	4.3	BRAVADA	401	402	403	512	512	514	676	677	678	393		459	457	1040	291
<b>OLDSMOBILE CARS</b>																			
76-68	V8	455	7.5	ALL MODELS	403	404	405	512	514	516	677	678	679	N/R		459	457	1040	291
67-65	V8	425	7.0	ALL MODELS	403	404	405	512	514	516	677	678	679	N/R		459	457	1040	291
79-77	V8	403	6.6	ALL MODELS	403	404	405	512	514	516	677	678	679	N/R		459	457	1040	291
75-65	V8	400	6.6	ALL MODELS	403	404	405	512	514	516	677	678	679	N/R		459	457	1040	291
92	V8	350	5.7	DELTA 88	403	404	405	512	514	516	677	678	679	N/R		459	457	1040	291
85-78	V8	350	5.7 (N)	DIESEL	403	404	405	512	514	516	677	678	679	N/R		-	-	-	-
80-68	V8	350	5.7	ALL MODELS	403	404	405	512	514	516	677	678	679	N/R		459	457	1040	291
90-80	V8	307	5.0	ALL MODELS	403	404	405	512	514	516	677	678	679	N/R		459	457	1040	291
92-77	V8	305	5.0	ALL MODELS	403	404	405	512	514	516	677	678	679	N/R		459	457	1040	291
83	V8	302	5.0	CUTLASS CALAIS	403	404	405	512	514	516	677	678	679	N/R		459	457	1040	291
79-78	V8	301	4.9	ALL MODELS	403	404	405	512	514	516	677	678	679	N/R		459	457	1040	291
82-81	V8	267	4.4	ALL MODELS	403	404	405	512	514	516	677	678	679	N/R		459	457	1040	291
85-79	V6	260	4.3 (T)	DIESEL	403	404	405	512	514	516	677	678	679	N/R		-	-	-	291
82-75	V8	260	4.3	ALL MODELS	403	404	405	512	514	516	677	678	679	N/R		459	457	1040	291
84-81	V6	252	4.1	ALL MODELS	403	404	405	512	514	516	677	678	679	N/R		459	457	1040	291
76-66	L6	250	4.1	ALL MODELS	403	404	405	512	514	516	677	678	679	N/R		459	457	1040	291
03-01	V8	244	4.0	AURORA	403	404	405	512	514	516	677	678	679	397		459	457	1040	291
00-95	V8	244	4.0	AURORA	403	404	405	512	514	516	677	678	679	N/R		459	457	1040	291
99-75	V6	231	3.8	ALL MODELS	403	404	405	512	514	516	677	678	679	N/R		459	457	1040	291
65-64	L6	225	3.7	ALL MODELS	403	404	405	512	514	516	677	678	679	N/R		459	457	1040	291
02-01	V6	214	3.5	AURORA	401	402	403	512	512	514	676	677	678	397		459	457	1040	291
02-00	V6	214	3.5	INTRIGUE	401	402	403	512	512	514	676	677	678	397		459	457	1040	291
99	V6	214	3.5	INTRIGUE	401	402	403	512	512	514	676	677	678	390 (14)		-	-	-	-
63-61	V8	215	3.5	ALL MODELS	401	402	403	512	512	514	676	677	678	390 (14)		459	457	1040	291
04-02	V6	207	3.4	SILHOUETTE	401	402	403	512	512	514	676	677	678	397		459	457	1040	291
01-00	V6	207	3.4	SILHOUETTE APV	401	402	403	512	512	514	676	677	678	397		459	457	1040	291
04-00	V6	207	3.4	ALERO	401	402	403	512	512	514	676	677	678	390		459	457	1040	291
99-91	V6	207	3.4	ALL MODELS	401	402	403	512	512	514	676	677	678	390 (14)		459	457	1040	291
93-89	V6	204	3.3	ALL MODELS	401	402	403	512	512	514	676	677	678	390 (14)		459	457	1040	291
99-89	V6	189	3.1	ALL MODELS	401	402	403	512	512	514	676	677	678	390 (14)		459	457	1040	291
88-82	V6	181	3.0	ALL MODELS	401	402	403	512	512	514	676	677	678	390 (14)		459	457	1040	291
89-79	V6	173	2.8	ALL MODELS	401	402	403	512	512	514	676	677	678	390 (14)		459	457	1040	291
95-79	L4	151	2.5	ALL MODELS	401	402	403	512	512	512	676	677	677	390 (14)		459	459	457	291 (11)
01-96	L4	146	2.4	ALL MODELS	401	402	403	512	512	512	676	677	677	390 (14)		459	459	457	291
95-87	L4	138	2.3	ALL MODELS	401	402	403	512	512	512	676	677	677	390 (14)		459	459	457	291
77-76	L4	140	2.3	ALL MODELS	401	402	403	512	512	512	676	677	677	390 (14)		459	459	457	291
96-93	L4	134	2.2	ALL MODELS	401	402	403	512	512	512	676	677	677	390 (14)		459	459	457	291
88-83	L4	122	2.0	ALL MODELS	401	402	403	512	512	512	676	677	677	390 (14)		459	459	457	291
86-82	L4	112	1.8	ALL MODELS	401	402	403	512	512	512	676	677	677	390 (14)		459	459	457	291
<b>PLYMOUTH CARS AND MINI VANS</b>																			
78-66	V8	440	7.2	ALL MODELS	404	405	1015	514	516	516	677	678	679	N/R		459	457	1040	291 (8)
71-63	V8	426	7.0	ALL MODELS	403	404	405	512	514	516	677	678	679	N/R		459	457	1040	291

(1) Remote filter mount kit is optional unless otherwise noted.

(11) No application for engines with internal oil filters.

(8) Remote kit is required for 440 engines in van applications.

(14) 1991 and later vehicles with 5/8" hex on trans line fittings requires kit #390.

# TRANSMISSION/ENGINE OIL COOLERS

## Application Guide

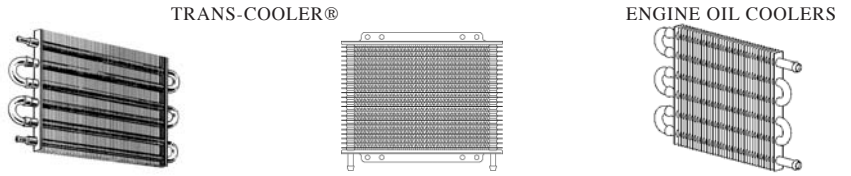

YEAR	TYPE	CID	ENGINE LITERS (VIN)	APPLICATION	ULTRA-COOL®			HIGH PERFORMANCE			RAPID-COOL®			REQUIRED TRANS FITTING KIT		REMOTE ENGINE KIT (1)			
					LIGHT DUTY	MEDIUM DUTY	HEAVY DUTY	LIGHT DUTY	MEDIUM DUTY	HEAVY DUTY	LIGHT DUTY	MEDIUM DUTY	HEAVY DUTY	COOL	NOTE	LIGHT DUTY	MEDIUM DUTY	HEAVY DUTY	COOLER NOTE
<b>PLYMOUTH CARS AND MINI VANS (Cont'd)</b>																			
78-72	V8	400	6.6	ALL MODELS	403	404	405	512	514	516	677	678	679	N/R		459	457	1040	291
71-60	V8	383	6.4	ALL MODELS	403	404	405	512	514	516	677	678	679	N/R		459	457	1040	291
64-60	V8	361	5.9	ALL MODELS	403	404	405	512	514	516	677	678	679	N/R		459	457	1040	291
80-71	V8	360	5.9	ALL MODELS	403	404	405	512	514	516	677	678	679	N/R		459	457	1040	291
73-68	V8	340	5.6	ALL MODELS	403	404	405	512	514	516	677	678	679	N/R		459	457	1040	291
89-60	V8	318	5.2	ALL MODELS	403	404	405	512	514	516	677	678	679	N/R		459	457	1040	291
69-64	V8	273	4.5	ALL MODELS	403	404	405	512	514	516	677	678	679	N/R		459	457	1040	291
99-98	V6	230	3.8	VOYAGER	401	402	403	512	512	514	676	677	678	N/R		459	457	1040	291
95-94	V6	230	3.8	GRAND VOYAGER	401	402	403	512	514	516	677	678	679	N/R		459	457	1040	291
83-60	L6	225	3.7	ALL MODELS	401	402	403	512	512	514	676	677	678	N/R		459	457	1040	291
00-90	V6	201	3.3	GRAND VOYAGER	401	402	403	512	512	514	676	677	678	N/R		459	457	1040	291
00-91	V6	201	3.3	VOYAGER	401	402	403	512	512	514	676	677	678	N/R		459	457	1040	291
74-70	L6	198	3.2	ALL MODELS	401	402	403	512	512	514	676	677	678	N/R		459	457	1040	291
00-88	V6	181	3.0	GRAND VOYAGER	401	402	403	512	512	514	676	677	678	N/R		459	457	1040	291
00-87	V6	181	3.0	VOYAGER	401	402	403	512	512	514	676	677	678	N/R		459	457	1040	291
94-92	V6	181	3.0	SUNDANCE	401	402	403	512	512	514	676	677	678	N/R		459	457	1040	291
95-89	V6	181	3.0	ACCLAIM	401	402	403	512	512	514	676	677	678	N/R		459	457	1040	291
69-60	L6	170	2.8	ALL MODELS	401	402	403	512	512	514	676	677	678	N/R		459	457	1040	291
86-78	L4	156	2.6	ALL MODELS	401	402	403	512	512	514	676	677	678	N/R		459	457	1040	291
87-84	L4	156	2.6	VOYAGER	401	402	403	512	512	514	676	677	678	N/R		459	457	1040	291
90-88	L4	153	2.5	GRAND VOYAGER	401	402	403	512	512	514	676	677	678	N/R		459	457	1040	291
95-87	L4	153	2.5	VOYAGER	401	402	403	512	512	514	676	677	678	N/R		459	457	1040	291
95-86	L4	153	2.5	ACCLAIM	401	402	403	512	512	514	676	677	678	N/R		459	457	1040	291
97-96	L4	148	2.4	GRAND VOYAGER	401	402	403	512	512	514	676	677	678	N/R		459	457	1040	291
00-96	L4	148	2.4	VOYAGER	401	402	403	512	512	514	676	677	678	N/R		459	457	1040	291
00-96	L4	148	2.4	BREEZE	401	402	403	512	512	514	676	677	678	N/R		459	457	1040	291
94-92	L4	148	2.4	COLT	401	402	403	512	512	514	676	677	678	N/R		459	457	1040	291
94-81	L4	135	2.2	ALL MODELS	401	402	403	512	512	514	676	677	678	N/R		459	457	1040	291
87-84	L4	135	2.2	VOYAGER	401	402	403	512	512	514	676	677	678	N/R		459	457	1040	291
82-76	L4	122	2.0	ARROW	401	402	403	512	512	514	676	677	678	N/R		459	457	1040	291
00-96	L4	122	2.0	BREEZE	401	402	403	512	512	514	676	677	678	N/R		459	457	1040	291
91-73	L4	122	2.0	COLT	401	402	403	512	512	514	676	677	678	N/R		459	457	1040	291
94-90	L4	122	2.0	LASER	401	402	403	512	512	514	676	677	678	N/R		459	457	1040	291
01-95	L4	122	2.0	NEON	401	402	403	512	512	514	676	677	678	N/R		459	457	1040	291
94-89	L4	112	1.8	COLT	401	402	403	512	512	514	676	677	678	N/R		459	457	1040	291
94-90	L4	107	1.8	LASER	401	402	403	512	512	514	676	677	678	N/R		459	457	1040	291
83-78	L4	104	1.7	HORIZON	401	402	403	512	512	514	676	677	678	N/R		459	457	1040	291
80-76	L4	98	1.6	ARROW	401	402	403	512	512	514	676	677	678	N/R		459	457	1040	291
82-79	L4	98	1.6	CHAMP	401	402	403	512	512	514	676	677	678	N/R		459	457	1040	291
90-76	L4	98	1.6	COLT	401	402	403	512	512	514	676	677	678	N/R		459	457	1040	291
86-83	L4	98	1.6	HORIZON	401	402	403	512	512	514	676	677	678	N/R		459	457	1040	291
79-78	L4	98	1.6	SAPPORO	401	402	403	512	512	514	676	677	678	N/R		459	457	1040	291
85-83	L4	98	1.6	TURISMO	401	402	403	512	512	514	676	677	678	N/R		459	457	1040	291
94-85	L4	90	1.5	COLT	401	402	403	512	512	514	676	677	678	N/R		459	457	1040	291
73-71	L4	90	1.5	CRICKET	401	402	403	512	512	514	676	677	678	N/R		459	457	1040	291
82-79	L4	86	1.4	CHAMP	401	402	403	512	512	514	676	677	678	N/R		459	457	1040	291
84-79	L4	86	1.4	COLT	401	402	403	512	512	514	676	677	678	N/R		459	457	1040	291

(1) Remote filter mount kit is optional unless otherwise noted.

# TRANSMISSION/ENGINE OIL COOLERS

## Application Guide

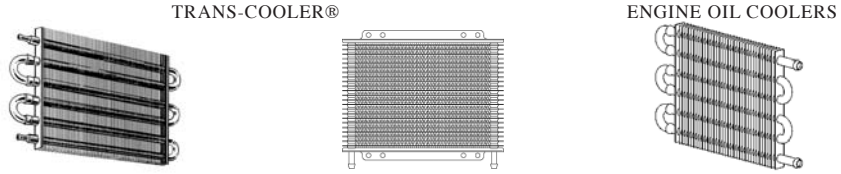

ULTRA-COOL® HIGH PERFORMANCE RAPID-COOL®

YEAR	TYPE	CID	ENGINE LITERS (VIN)	APPLICATION	ULTRA-COOL®			HIGH PERFORMANCE			RAPID-COOL®			REQUIRED TRANS FITTING KIT		REMOTE ENGINE KIT (1)			
					LIGHT DUTY	MEDIUM DUTY	HEAVY DUTY	LIGHT DUTY	MEDIUM DUTY	HEAVY DUTY	LIGHT DUTY	MEDIUM DUTY	HEAVY DUTY	COOL NOTE	LIGHT DUTY	MEDIUM DUTY	HEAVY DUTY	COOLER NOTE	
<b>PLYMOUTH TRUCKS AND VANS</b>																			
78-76	V8	440	7.2	PB200-PB300 VAN	403	404	405	512	514	516	677	678	679	N/R		459	457	1040	291
78-74	V8	440	7.2	TRAILDUSTER	404	405	1015	514	516	516	677	678	679	N/R		459	457	1040	291 (8)
78-76	V8	400	6.6	TRAILDUSTER	403	404	405	512	514	516	677	678	679	N/R		459	457	1040	291
78-76	V8	400	6.6	PB200-PB300 VAN	403	404	405	512	514	516	677	678	679	N/R		459	457	1040	291
83-81	V8	360	5.9	PB350 VAN	403	404	405	512	514	516	677	678	679	N/R		459	457	1040	291
83-74	V8	360	5.9	PB200-PB300 VAN	403	404	405	512	514	516	677	678	679	N/R		459	457	1040	291
81-74	V8	360	5.9	TRAILDUSTER	403	404	405	512	514	516	677	678	679	N/R		459	457	1040	291
81	V8	360	5.9	PB250 VAN	403	404	405	512	514	516	677	678	679	N/R		459	457	1040	291
80-74	V8	360	5.9	PB200 VAN	403	404	405	512	514	516	677	678	679	N/R		459	457	1040	291
80-74	V8	360	5.9	PB300 VAN	403	404	405	512	514	516	677	678	679	N/R		459	457	1040	291
78-74	V8	360	5.9	PB100 VAN	403	404	405	512	514	516	677	678	679	N/R		459	457	1040	291
83-81	V8	318	5.2	PB150 VAN	403	404	405	512	514	516	677	678	679	N/R		459	457	1040	291
83-81	V8	318	5.2	PB250 VAN	403	404	405	512	514	516	677	678	679	N/R		459	457	1040	291
83-81	V8	318	5.2	PB350 VAN	403	404	405	512	514	516	677	678	679	N/R		459	457	1040	291
81-74	V8	318	5.2	TRAILDUSTER	403	404	405	512	514	516	677	678	679	N/R		459	457	1040	291
80-74	V8	318	5.2	PB200 VAN	403	404	405	512	514	516	677	678	679	N/R		459	457	1040	291
80-74	V8	318	5.2	PB300 VAN	403	404	405	512	514	516	677	678	679	N/R		459	457	1040	291
79-74	V8	318	5.2	PB100 VAN	403	404	405	512	514	516	677	678	679	N/R		459	457	1040	291
83-81	L6	225	3.7	PB150 VAN	401	402	403	512	512	514	676	677	678	N/R		459	457	1040	291
80-75	L6	225	3.7	TRAILDUSTER	401	402	403	512	514	516	677	678	679	N/R		459	457	1040	291
80-74	L6	225	3.7	PB100 VAN	401	402	403	512	512	514	676	677	678	N/R		459	457	1040	291
80-74	L6	225	3.7	PB200 VAN	401	402	403	512	512	514	676	677	678	N/R		459	457	1040	291
83-80	L6	225	3.7	PB250 VAN	401	402	403	512	512	514	676	677	678	N/R		459	457	1040	291
<b>PONTIAC CARS AND MINIVANS</b>																			
76-70	V8	455	7.5	ALL MODELS	403	404	405	512	514	516	677	678	679	N/R		459	457	1040	291
69-67	V8	428	7.0	ALL MODELS	403	404	405	512	514	516	677	678	679	N/R		459	457	1040	291
66-63	V8	421	6.9	ALL MODELS	403	404	405	512	514	516	677	678	679	N/R		459	457	1040	291
79-77	V8	403	6.6	ALL MODELS	403	404	405	512	514	516	677	678	679	N/R		459	457	1040	291
79-67	V8	400	6.6	ALL MODELS	403	404	405	512	514	516	677	678	679	N/R		459	457	1040	291
66-60	V8	389	6.4	ALL MODELS	403	404	405	512	514	516	677	678	679	N/R		459	457	1040	291
02-87	V8	350	5.7	FIREBIRD	403	404	405	512	514	516	677	678	679	390 (14)		459	457	1040	291
85-80	V8	350	5.7	DIESEL	403	404	405	512	514	516	677	678	679	N/R		-	-	-	-
85	V8	350	5.7	PARISIENNE	403	403	404	512	512	514	676	677	678	N/R		459	457	1040	291
80-68	V8	350	5.7	ALL MODELS	403	403	404	512	512	514	676	677	678	N/R		459	457	1040	291
67-63	V8	326	5.3	ALL MODELS	403	403	404	512	512	514	676	677	678	N/R		459	457	1040	291
81-71	V8	307	5.0	ALL MODELS	403	403	404	512	512	514	676	677	678	N/R		459	457	1040	291
92-76	V8	305	5.0	ALL MODELS	403	403	404	512	512	514	676	677	678	390 (14)		459	457	1040	291
81-77	V8	301	4.9	ALL MODELS	403	403	404	512	512	514	676	677	678	N/R		459	457	1040	291
82-79	V8	267	4.4	ALL MODELS	403	403	404	512	512	514	676	677	678	N/R		459	457	1040	291
87-85	V6	262	4.3	ALL MODELS	403	403	404	512	512	514	676	677	678	N/R		459	457	1040	291
85-82	V6	260	4.3	6000 DIESEL	403	404	405	512	514	516	677	678	679	N/R		-	-	-	-
81-80	V8	265	4.3	ALL MODELS	403	403	404	512	512	514	676	677	678	N/R		459	457	1040	291
76-75	V8	260	4.3	ALL MODELS	403	403	404	512	512	514	676	677	678	N/R		459	457	1040	291
82	V6	252	4.1	ALL MODELS	403	403	404	512	512	514	676	677	678	N/R		459	457	1040	291
79-68	L6	250	4.1	ALL MODELS	403	403	404	512	512	514	676	677	678	N/R		459	457	1040	291
2006	V6	237	3.9	MONTANA SV6	403	403	404	512	512	514	676	677	678	397		459	457	1040	291
05-01	V6	231	3.8	BONNEVILLE	403	403	404	512	512	514	676	677	678	397		459	457	1040	291

(1) Remote filter mount kit is optional unless otherwise noted.  
 (14) 1991 and later vehicles with 5/8" hex on trans line fittings requires kit #390.

(8) Remote kit is required for 440 engines in van applications.

# TRANSMISSION/ENGINE OIL COOLERS

## Application Guide

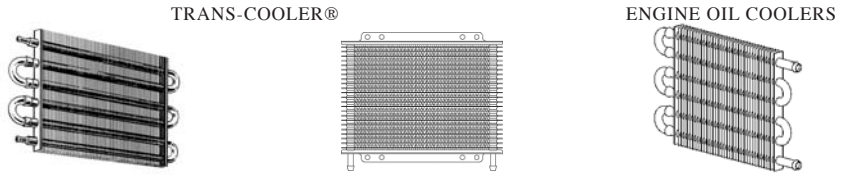

YEAR	TYPE	CID	ENGINE LITERS (VIN)	APPLICATION	ULTRA-COOL®			HIGH PERFORMANCE			RAPID-COOL®			REQUIRED TRANS		REMOTE ENGINE			
					LIGHT DUTY	MEDIUM DUTY	HEAVY DUTY	LIGHT DUTY	MEDIUM DUTY	HEAVY DUTY	LIGHT DUTY	MEDIUM DUTY	HEAVY DUTY	FITTING KIT	COOLR NOTE	LIGHT DUTY	MEDIUM DUTY	HEAVY DUTY	KIT (1)
<b>PONTIAC CARS AND MINIVANS (Cont'd)</b>																			
07-00	V6	231	3.8	GRAND PRIX	403	403	404	512	512	514	676	677	678	397		459	457	1040	291
03-00	V6	231	3.8	FIREBIRD	403	403	404	512	512	514	676	677	678	390	(14)	459	457	1040	291
99-90	V6	231	3.8	ALL MODELS	403	403	404	512	512	514	676	677	678	390	(14)	459	457	1040	291
89-76	V6	231	3.8	ALL MODELS	403	403	404	512	512	514	676	677	678	N/R		459	457	1040	291
83-80	V6	229	3.8	ALL MODELS	403	403	404	512	512	514	676	677	678	N/R		459	457	1040	291
83-80	V6	229	3.8	ALL MODELS	403	403	404	512	512	514	676	677	678	N/R		459	457	1040	291
67-66	L6	230	3.8	FIREBIRD	403	403	404	512	512	514	676	677	678	N/R		459	457	1040	291
65-64	L6	215	3.5	ALL MODELS	403	403	404	512	512	514	676	677	678	N/R		459	457	1040	291
05-06	V6	211	3.5	MONTANA SV6	403	403	404	512	512	514	676	677	678	397		459	457	1040	291
05-01	V6	207	3.4	AZTEK	403	403	404	512	512	514	676	677	678	397		459	457	1040	291
07-06	V6	207	3.4	TORRENT	403	403	404	512	512	514	676	677	678	397		459	457	1040	291
05-00	V6	207	3.4	MONTANA	403	403	404	512	512	514	676	677	678	397		459	457	1040	291
99	V6	207	3.4	MONTANA	401	403	404	512	512	514	676	677	678	390		459	457	1040	291
05-00	V6	207	3.4	GRAND AM	403	403	404	512	512	514	676	677	678	390		459	457	1040	291
98-96	V6	207	3.4	TRANS SPORT	403	403	404	512	512	514	676	677	678	390		459	457	1040	291
96-91	V6	207	3.4	GRAND PRIX	403	403	404	512	512	514	676	677	678	390		459	457	1040	291
95-93	V6	207	3.4	FIREBIRD	403	403	404	512	512	514	676	677	678	N/R		459	457	1040	291
93-92	V6	204	3.3	GRAND AM	403	403	404	512	512	514	676	677	678	N/R		459	457	1040	291
79-78	V6	200	3.3	GRAND LEMANS	403	403	404	512	512	514	676	677	678	N/R		459	457	1040	291
79-78	V6	200	3.3	LEMANS	403	403	404	512	512	514	676	677	678	N/R		459	457	1040	291
03-00	V6	189	3.1	GRAND PRIX	403	403	404	512	512	514	676	677	678	397		459	457	1040	291
99-89	V6	189	3.1	ALL MODELS	401	402	403	512	512	512	676	677	677	390	(14)	459	459	457	291
95-90	V6	189	3.1	TRANS SPORT	401	402	403	512	512	512	676	677	677	390	(14)	459	459	457	291
87-85	V6	181	3.0	GRAND AM	401	402	403	512	512	512	676	677	677	N/R		459	459	457	291
89-80	V6	173	2.8	6000	401	402	403	512	512	512	676	677	677	N/R		459	459	457	291
91-77	L4	151	2.5	ALL MODELS	401	402	403	512	512	512	676	677	677	390	(14)	459	459	457	291 (11)
01-96	L4	146	2.4	GRAND AM	401	402	403	512	512	512	676	677	677	390	(14)	459	459	457	291
02-98	L4	146	2.4	SUNFIRE	401	402	403	512	512	512	676	677	677	390	(14)	459	459	457	291
95-88	L4	138	2.3	GRAND AM	401	402	403	512	512	512	676	677	677	390	(14)	459	459	457	291
77-75	L4	140	2.3	ASTRE, SUNBIRD	401	402	403	512	512	512	676	677	677	N/R		459	459	457	291
04-95	L4	134	2.2	SUNFIRE	401	402	403	512	512	512	676	677	677	390	(14)	459	459	457	291
04-02	L4	134	2.2	GRAND AM	401	402	403	512	512	512	676	677	677	390	(14)	459	459	457	291
91-90	L4	134	2.2	TEMPEST	401	402	403	512	512	512	676	677	677	390	(14)	459	459	457	291
94-83	L4	122	2.0	ALL MODELS	401	402	403	512	512	512	676	677	677	390	(14)	459	459	457	291
86-81	L4	112	1.8	SUNBIRD	401	402	403	512	512	512	676	677	677	N/R		459	459	457	291
07-05	L4	112	1.8	VIBE	-	-	-	-	-	-	-	-	-			-	-	-	-
87-82	L4	98	1.6	T-1000	401	402	403	512	512	512	676	677	677	N/R		459	459	457	291
97-83	L4	98	1.6	ALL MODELS	401	402	403	512	512	512	676	677	677	390	(14)	459	459	457	291
87-76	L4	98	1.6	ACADIAN	401	402	403	512	512	512	676	677	677	N/R		459	459	457	291
88-85	L4	92	1.5	SUNBURST	401	402	403	512	512	512	676	677	677	N/R		459	459	457	291
77-76	L4	85	1.4	ACADIAN	401	402	403	512	512	512	676	677	677	N/R		459	459	457	291
<b>SATURN</b>																			
2005	V6	215	3.5	VUE	-	-	-	-	-	-	-	-	-			-	-	-	-
04-00	V6	184	3.0	VUE, L, LS, LW SERIES	401	402	403	512	512	512	676	677	677	N/R		-	-	-	-
05-00	L4	135	2.2	ION, VUE, L, LS, LW SERIES	401	402	403	512	512	512	676	677	677	N/R		459	459	457	291
02-91	L4	117	1.9	SC, SW, SL, SERIES	401	402	403	512	512	512	676	677	677	N/R		459	459	457	291

(1) Remote filter mount kit is optional unless otherwise noted.

(14) 1991 and later vehicles with 5/8" hex on trans line fittings requires kit #390.

(11) No application for engines with internal oil filters.

# TRANSMISSION/ENGINE OIL COOLERS

## Application Guide

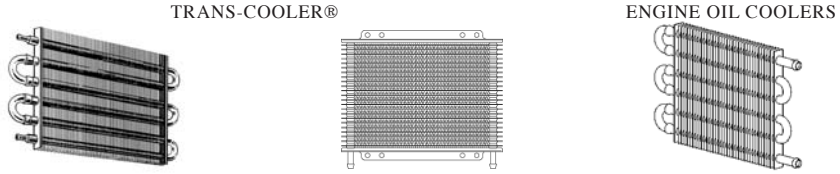

ULTRA-COOL® HIGH PERFORMANCE RAPID-COOL®

YEAR	TYPE	CID	ENGINE LITERS (VIN)	APPLICATION	ULTRA-COOL®			HIGH PERFORMANCE			RAPID-COOL®			REQUIRED TRANS		REMOTE ENGINE			
					LIGHT DUTY	MEDIUM DUTY	HEAVY DUTY	LIGHT DUTY	MEDIUM DUTY	HEAVY DUTY	LIGHT DUTY	MEDIUM DUTY	HEAVY DUTY	FITTING KIT	COOLR NOTE	LIGHT DUTY	MEDIUM DUTY	HEAVY DUTY	KIT (1)
<b>SUBARU</b>																			
97-92	H6	204	3.3	SVX	401	402	403	512	512	514	676	677	678	N/R		459	457	457	291 (9)
05-01	H6	184	3.0	OUTBACK	401	402	403	512	512	514	676	677	678	N/R		459	457	457	291 (9)
91-88	H6	164	2.7	XT6	401	402	403	512	512	514	676	677	678	N/R		459	457	457	291 (9)
01-96	H4	151	2.5	LEGACY	401	402	403	512	512	514	676	677	678	N/R		459	457	457	291 (9)
05-01	H4	151	2.5	OUTBACK	401	402	403	512	512	514	676	677	678	N/R		459	457	457	291 (9)
05-98	H4	151	2.5	IMPREZA	401	402	403	512	512	514	676	677	678	N/R		459	457	457	291 (9)
05-98	H4	151	2.5	FORESTER, BAJA	401	402	403	512	512	514	676	677	678	N/R		459	457	457	291 (9)
99-90	H4	136	2.2	LEGACY	401	402	403	512	512	514	676	677	678	N/R		459	457	457	291 (9)
01-96	H4	136	2.2	IMPREZA	401	402	403	512	512	514	676	677	678	N/R		459	457	457	291 (9)
05-02	H4	121	2.0	IMPREZA WRX	401	402	403	512	512	514	676	677	678	N/R		459	457	457	291 (9)
91-85	H4	109	1.8	XT	401	402	403	512	512	514	676	677	678	N/R		459	457	457	291 (9)
89-86	H4	109	1.8	RX	401	402	403	512	512	514	676	677	678	N/R		459	457	457	291 (9)
94-90	H4	109	1.8	LOYALE	401	402	403	512	512	514	676	677	678	N/R		459	457	457	291 (9)
97-93	H4	109	1.8	IMPREZA	401	402	403	512	512	514	676	677	678	N/R		459	457	457	291 (9)
89-85	H4	109	1.8	GL-10	401	402	403	512	512	514	676	677	678	N/R		459	457	457	291 (9)
89-80	H4	109	1.8	GL,DL	401	402	403	512	512	514	676	677	678	N/R		459	457	457	291 (9)
87-81	H4	109	1.8	BRAT	401	402	403	512	512	514	676	677	678	N/R		459	457	457	291 (9)
87-77	H4	98	1.6	STANDARD	401	402	403	512	512	514	676	677	678	N/R		459	457	457	291 (9)
87-79	H4	98	1.6	GL	401	402	403	512	512	514	676	677	678	N/R		459	457	457	291 (9)
79-76	H4	98	1.6	GF,FE	401	402	403	512	512	514	676	677	678	N/R		459	457	457	291 (9)
84-80	H4	98	1.6	DL	401	402	403	512	512	514	676	677	678	N/R		459	457	457	291 (9)
80-78	H4	98	1.6	BRAT	401	402	403	512	512	514	676	677	678	N/R		459	457	457	291 (9)
94-87	L3	73	1.2	JUSTY	401	402	403	512	512	514	676	677	678	N/R		459	457	457	291 (9)
<b>TOYOTA CARS</b>																			
2005	V6	202	3.3	CAMRY	401	402	403	512	512	514	676	677	678	N/R		459	457	1040	291
2005	V6	202	3.3	SOLARA	401	402	403	512	512	514	676	677	678	N/R		459	457	1040	291
03-99	V6	184	3.0	SOLARA	401	402	403	512	512	514	676	677	678	N/R		459	457	1040	291
05-95	V6	184	3.0	AVALON	401	402	403	512	512	514	676	677	678	N/R		459	457	1040	291
05-92	V6	184	3.0	CAMRY	401	402	403	512	512	514	676	677	678	N/R		459	457	1040	291
98-86	L6	184	3.0	SUPRA	401	402	403	512	512	514	676	677	678	N/R		459	457	1040	291
92-89	L6	184	3.0	CRESSIDA	401	402	403	512	512	514	676	677	678	N/R		459	457	1040	291
92-81	V6	168	2.8	CRESSIDA	401	402	403	512	512	514	676	677	678	N/R		459	457	457	291
91-81	L6	172	2.8	SUPRA	401	402	403	512	512	514	676	677	678	N/R		459	457	457	291
80-78	L6	160	2.6	CRESSIDA	401	402	403	512	512	514	676	677	678	N/R		459	457	457	291
80-79	L6	160	2.6	SUPRA	401	402	403	512	512	514	676	677	678	N/R		459	457	457	291
92-88	V6	154	2.5	CAMRY	401	402	403	512	512	514	676	677	678	N/R		459	457	457	291
05-02	L4	147	2.4	CAMRY, SOLARA	401	402	403	512	512	514	676	677	678	N/R		459	457	457	291
97-91	L4	147	2.4	PREVIA	401	402	403	512	512	514	676	677	678	N/R		459	457	457	291
85-81	L4	147	2.4	CELICA	401	402	403	512	512	514	676	677	678	N/R		459	457	457	291
82-81	L4	147	2.4	CORONA	401	402	403	512	512	514	676	677	678	N/R		459	457	457	291
01-99	L4	135	2.2	SOLARA	401	402	403	512	512	514	676	677	678	N/R		459	457	457	291
01-92	L4	135	2.2	CAMRY	401	402	403	512	512	514	676	677	678	N/R		459	457	457	291
99-75	L4	135	2.2	CELICA	401	402	403	512	512	514	676	677	678	N/R		459	457	457	291
95-91	L4	135	2.2	MR2	401	402	403	512	512	514	676	677	678	N/R		459	457	457	291
80-75	L4	135	2.2	CORONA	401	402	403	512	512	514	676	677	678	N/R		459	457	457	291
95-91	L4	123	2.0	MR2	401	402	403	512	512	514	676	677	678	N/R		459	457	457	291
93-72	L4	123	2.0	CELICA	401	402	403	512	512	514	676	677	678	N/R		459	457	457	291

(1) Remote filter mount kit is optional unless otherwise noted.  
 (9) Some OEM filters will not seal on the oil filter adapter, Use Fram filter number PH3950 or equivalent.

# TRANSMISSION/ENGINE OIL COOLERS

## Application Guide

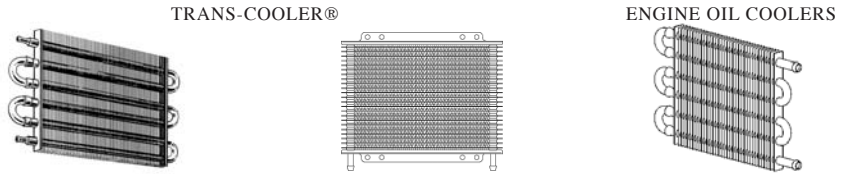

YEAR	TYPE	CID	ENGINE LITERS (VIN)	APPLICATION	ULTRA-COOL®			HIGH PERFORMANCE			RAPID-COOL®			REQUIRED TRANS FITTING KIT		REMOTE ENGINE KIT (1)			
					LIGHT DUTY	MEDIUM DUTY	HEAVY DUTY	LIGHT DUTY	MEDIUM DUTY	HEAVY DUTY	LIGHT DUTY	MEDIUM DUTY	HEAVY DUTY	COOLR NOTE	LIGHT DUTY	MEDIUM DUTY	HEAVY DUTY		
<b>TOYOTA CARS (Cont'd)</b>																			
92-83	L4	123	2.0	CAMRY	401	402	403	512	512	514	676	677	678	N/R		459	457	457	291
86	L4	123	2.0	DIESEL CAMRY	401	402	403	512	512	514	676	677	678	N/R		459	457	457	291
74-72	L4	123	2.0	CORONA	401	402	403	512	512	514	676	677	678	N/R		459	457	457	291
04-00	L4	111	1.8	CELICA	401	402	403	512	512	514	676	677	678	N/R		459	457	457	291
05-93	L4	111	1.8	COROLLA	401	402	403	512	512	514	676	677	678	N/R		459	457	457	291
05-00	L4	111	1.8	MR2 SPYDER	401	402	403	512	512	514	676	677	678	N/R		459	457	457	291
86-84	L4	111	1.8	CAMRY	401	402	403	512	512	514	676	677	678	N/R		459	457	457	291
85-84	L4	111	1.8	COROLLA	401	402	403	512	512	514	676	677	678	N/R		459	457	457	291
82-80	L4	111	1.8	COROLLA	401	402	403	512	512	514	676	677	678	N/R		459	457	457	291
97-83	L4	98	1.6	COROLLA	401	402	403	512	512	514	676	677	678	N/R		459	457	457	291
93-90	L4	98	1.6	CELICA	401	402	403	512	512	514	676	677	678	N/R		459	457	457	291
89-85	L4	98	1.6	MR2	401	402	403	512	512	514	676	677	678	N/R		459	457	457	291
79-71	L4	98	1.6	COROLLA	401	402	403	512	512	514	676	677	678	N/R		459	457	457	291
05-01	L4	92	1.5	PRIUS	401	402	403	512	512	514	676	677	678	N/R		459	457	457	291
05-00	L4	92	1.5	ECHO	401	402	403	512	512	514	676	677	678	N/R		459	457	457	291
99-92	L4	92	1.5	PASEO	401	402	403	512	512	514	676	677	678	N/R		459	457	457	291
98-80	L4	92	1.5	TERCEL	401	402	403	512	512	514	676	677	678	N/R		459	457	457	291
84-81	L4	80	1.3	STARLET	401	402	403	512	512	514	676	677	678	N/R		459	457	457	291
79-69	L4	74	1.2	COROLLA	401	402	403	512	512	514	676	677	678	N/R		459	457	457	291
<b>TOYOTA TRUCKS AND SUVs</b>																			
2007	V8	350	5.7	TUNDRA	-	-	-	-	-	-	-	-	-			-	-	-	-
07-03	V8	285	4.7	4 RUNNER, 4WD ONLY	401	402	403	512	512	514	676	677	678	N/R		-	-	-	-
07-01	V8	285	4.7	SEQUOIA	401	402	403	512	514	516	677	678	679	N/R		459	457	1040	291
07-98	V8	285	4.7	LAND CRUISER	401	402	403	512	514	516	677	678	679	N/R		459	457	1040	291
07-00	V8	285	4.7	TUNDRA	401	402	403	512	514	516	677	678	679	N/R		459	457	1040	291
97-93	L6	276	4.5	LAND CRUISER	401	402	403	512	514	516	677	678	679	N/R		459	457	1040	291
87-75	L6	258	4.2	LAND CRUISER	401	402	403	512	514	516	677	678	679	N/R		459	457	1040	291
2007	V6	246	4.0	FJ CRUISER	401	402	403	512	514	516	677	678	679	N/R		-	-	-	-
07-04	V6	246	4.0	TUNDRA	401	402	403	512	514	516	677	678	679	N/R		-	-	-	-
07-05	V6	246	4.0	TACOMA	401	402	403	512	514	516	677	678	679	N/R		-	-	-	-
07-03	V6	246	4.0	4 RUNNER, W/ 4WD ONLY	401	402	403	512	514	516	677	678	679	N/R		-	-	-	-
92-88	L6	246	4.0	LAND CRUISER	401	402	403	512	514	516	677	678	679	N/R		459	457	1040	291
74-69	L6	239	3.9	LAND CRUISER	401	402	403	512	514	516	677	678	679	N/R		459	457	1040	291
07-05	V6	215	3.5	RAV 4	401	402	403	512	512	514	676	677	678	N/R		-	-	-	-
02-96	V6	209	3.4	4 RUNNER, All W/ 4WD ONLY	401	402	403	512	512	514	676	677	678	N/R		-	-	-	-
04-95	V6	209	3.4	TACOMA	401	402	403	512	512	514	676	677	678	N/R		-	-	-	-
05-00	V6	209	3.4	TUNDRA	401	402	403	512	512	514	676	677	678	N/R		-	-	-	-
98-95	V6	209	3.4	T100	401	402	403	512	512	514	676	677	678	N/R		-	-	-	-
85-81	L4	209	3.4	LAND CRUISER	401	402	403	512	512	514	676	677	678	N/R		-	-	-	-
07-04	V6	202	3.3	HIGHLANDER	401	402	403	512	512	514	676	677	678	N/R		-	-	-	-
2003	V6	184	3.0	HIGHLANDER	401	402	403	512	512	514	676	677	678	N/R		-	-	-	-
95-88	V6	184	3.0	4 RUNNER	401	402	403	512	512	514	676	677	678	N/R		459	459	457	291
95-88	V6	184	3.0	PICKUP	401	402	403	512	512	514	676	677	678	N/R		459	459	457	291
94-93	V6	184	3.0	T100	401	402	403	512	512	514	676	677	678	N/R		459	459	457	291
07-95	L4	166	2.7	TACOMA	401	402	403	512	512	514	676	677	678	N/R		459	459	457	291
00-96	L4	166	2.7	4 RUNNER	401	402	403	512	512	514	676	677	678	N/R		459	459	457	291
98-94	L4	166	2.7	T100	401	402	403	512	512	514	676	677	678	N/R		459	459	457	291

(1) Remote filter mount kit is optional unless otherwise noted.

# TRANSMISSION/ENGINE OIL COOLERS

## Application Guide

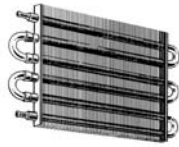

TRANS-COOLER®

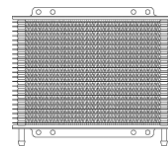

ENGINE OIL COOLERS

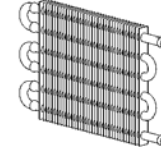

ULTRA-COOL®

HIGH PERFORMANCE

RAPID-COOL®

YEAR	TYPE	CID	ENGINE LITERS (VIN)	APPLICATION	ULTRA-COOL®			HIGH PERFORMANCE			RAPID-COOL®			REQUIRED FITTING KIT	TRANS COOL NOTE	REMOTE ENGINE KIT (1)			ENGINE COOLER NOTE
					LIGHT DUTY	MEDIUM DUTY	HEAVY DUTY	LIGHT DUTY	MEDIUM DUTY	HEAVY DUTY	LIGHT DUTY	MEDIUM DUTY	HEAVY DUTY			LIGHT DUTY	MEDIUM DUTY	HEAVY DUTY	
<b>TOYOTA TRUCKS AND SUVS (Cont'd)</b>																			
07-04	L4	147	2.4	RAV 4	401	402	403	512	512	514	676	677	678	N/R		-	-	-	-
07-01	L4	147	2.4	HIGHLANDER	401	402	403	512	512	514	676	677	678	N/R		-	-	-	-
04-95	L4	147	2.4	TACOMA	401	402	403	512	512	514	676	677	678	N/R		-	-	-	-
95-84	L4	147	2.4	4 RUNNER	401	402	403	512	512	514	676	677	678	N/R	459	459	457	291	
95-81	L4	147	2.4	PICKUP	401	402	403	512	512	514	676	677	678	N/R	459	459	457	291	
87-84	L4	147	2.4	DIESEL PICKUP	401	402	403	512	512	514	676	677	678	N/R	459	459	457	291	
87	L4	209	2.4	DIESEL LANDCRUISER	401	402	403	512	512	514	676	677	678	N/R	459	459	457	291	
83-81	L4	135	2.2	PICKUP	401	402	403	512	512	514	676	677	678	N/R	459	459	457	291	
80-75	L4	135	2.2	PICKUP	401	402	403	512	512	514	676	677	678	N/R	459	459	457	291	
03-96	L4	123	2.0	RAV4	401	402	403	512	512	514	676	677	678	N/R	459	459	457	291	
74-72	L4	123	2.0	PICKUP	401	402	403	512	512	514	676	677	678	N/R	459	459	457	291	
71-70	L4	117	1.9	PICKUP	401	402	403	512	512	514	676	677	678	N/R	459	459	457	291	
<b>TOYOTA VANS</b>																			
2007	V6	215	3.5	SIENNA	401	402	403	512	512	514	676	677	678	N/R	459	459	457	291	
06-04	V6	202	3.3	SIENNA	401	402	403	512	512	514	676	677	678	N/R	459	459	457	291	
03-98	V6	184	3.0	SIENNA	401	402	403	512	512	514	676	677	678	N/R	459	459	457	291	
89-86	L4	135	2.2	VAN	401	402	403	512	512	514	676	677	678	N/R	459	459	457	291	
88	L4	147	2.4	VAN WAGON	401	402	403	512	512	514	676	677	678	N/R	459	459	457	291	
88	L4	137	2.3	VAN WAGON	401	402	403	512	512	514	676	677	678	N/R	459	459	457	291	
85-84	L4	123	2.0	VAN	401	402	403	512	512	514	676	677	678	N/R	459	459	457	291	
<b>VOLKSWAGEN</b>																			
05-04	V8	258	4.2	TOUAREG	-	-	-	-	-	-	-	-	-	-	-	-	-	-	
04-02	W8	244	4.0	PASSAT	-	-	-	-	-	-	-	-	-	-	-	-	-	-	
05-04	V6	195	3.2	TOUAREG	-	-	-	-	-	-	-	-	-	-	-	-	-	-	
95-92	V6	172	2.8	CORRADO	-	-	-	-	-	-	-	-	-	-	459	459	457	291	
04-97	V6	172	2.8	EUROVAN	-	-	-	-	-	-	-	-	-	-	459	459	457	291	
05-95	V6	172	2.8	GOLF	-	-	-	-	-	-	-	-	-	-	459	459	457	291	
04-94	V6	172	2.8	JETTA	-	-	-	-	-	-	-	-	-	-	459	459	457	291	
05-93	V6	172	2.8	PASSAT	-	-	-	-	-	-	-	-	-	-	459	459	457	291	
99-92	L5	150	2.5	EUROVAN, TRANSPORTER	-	-	-	-	-	-	-	-	-	-	459	459	457	291	
96-93	L5	146	2.4	EUROVAN, TRANSPORTER	-	-	-	-	-	-	-	-	-	-	459	459	457	291	
88-83	L5	135	2.2	QUANTUM	-	-	-	-	-	-	-	-	-	-	459	459	457	291	
92-86	H4	129	2.1	VANAGON	-	-	-	-	-	-	-	-	-	-	459	459	457	291	
07-98	L4	122	2.0	BEETLE	-	-	-	-	-	-	-	-	-	-	-	-	-	-	
03-95	L4	122	2.0	CABRIO, CABRIOLET	-	-	-	-	-	-	-	-	-	-	459	459	457	291	
07-90	L4	122	2.0	GOLF, JETTA	-	-	-	-	-	-	-	-	-	-	459	459	457	291	
96-90	L4	122	2.0	PASSAT	-	-	-	-	-	-	-	-	-	-	459	459	457	291	
06-00	L4	116	1.9	BEETLE	-	-	-	-	-	-	-	-	-	-	-	-	-	-	
04-93	L4	116	1.9	GOLF, DIESEL	-	-	-	-	-	-	-	-	-	-	-	-	-	-	
06-93	L4	116	1.9	JETTA, DIESEL	-	-	-	-	-	-	-	-	-	-	-	-	-	-	
98-92	L4	116	1.9	PASSAT, DIESEL	-	-	-	-	-	-	-	-	-	-	-	-	-	-	
05-99	L4	111	1.8	BEETLE	-	-	-	-	-	-	-	-	-	-	459	459	457	291	
93-85	L4	111	1.8	CABRIOLET	-	-	-	-	-	-	-	-	-	-	459	459	457	291	
92-90	L4	111	1.8	CORRADO	-	-	-	-	-	-	-	-	-	-	459	459	457	291	
93-87	L4	111	1.8	FOX	-	-	-	-	-	-	-	-	-	-	459	459	457	291	
05-85	L4	111	1.8	GOLF	-	-	-	-	-	-	-	-	-	-	459	459	457	291	
05-84	L4	111	1.8	JETTA	-	-	-	-	-	-	-	-	-	-	459	459	457	291	

(1) Remote filter mount kit is optional unless otherwise noted.

# TRANSMISSION/ENGINE OIL COOLERS

## Application Guide

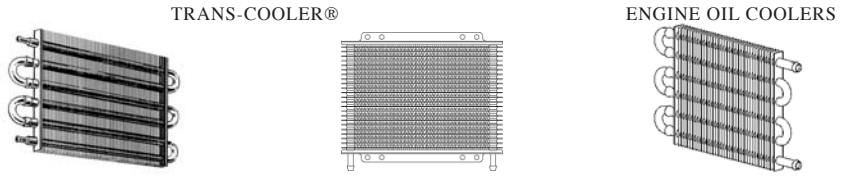

YEAR	TYPE	CID	ENGINE LITERS (VIN)	APPLICATION	ULTRA-COOL®			HIGH PERFORMANCE			RAPID-COOL®			REQUIRED TRANS FITTING KIT		TRANS COOL NOTE		REMOTE ENGINE KIT (1)		ENGINE COOLER NOTE	
					LIGHT DUTY	MEDIUM DUTY	HEAVY DUTY	LIGHT DUTY	MEDIUM DUTY	HEAVY DUTY	LIGHT DUTY	MEDIUM DUTY	HEAVY DUTY	LIGHT DUTY	MEDIUM DUTY	HEAVY DUTY	LIGHT DUTY	MEDIUM DUTY	HEAVY DUTY		
<b>VOLKSWAGEN (Cont'd)</b>																					
05-91	L4	111	1.8	PASSAT	-	-	-	-	-	-	-	-	-	-	-	-	459	459	457	291	
89-83	L4	111	1.8	SCIROCCO	-	-	-	-	-	-	-	-	-	-	-	-	459	459	457	291	
84-81	L4	104	1.7	RABBIT	-	-	-	-	-	-	-	-	-	-	-	-	459	459	457	291	
81-76	L4	97	1.6	DASHER	-	-	-	-	-	-	-	-	-	-	-	-	459	459	457	291	
92-85	L4	97	1.6	DIESEL GOLF	-	-	-	-	-	-	-	-	-	-	-	-	459	459	457	291	
92-80	L4	97	1.6	DIESEL JETTA	-	-	-	-	-	-	-	-	-	-	-	-	459	459	457	291	
85-82	L4	97	1.6	DIESEL QUANTUM	-	-	-	-	-	-	-	-	-	-	-	-	459	459	457	291	
84-81	L4	97	1.6	DIESEL RABBIT	-	-	-	-	-	-	-	-	-	-	-	-	459	459	457	291	
84-81	L4	97	1.6	RABBIT	-	-	-	-	-	-	-	-	-	-	-	-	459	459	457	291	
80-76	L4	97	1.6	SCIROCCO	-	-	-	-	-	-	-	-	-	-	-	-	459	459	457	291	
80-74	L4	92	1.5	DASHER	-	-	-	-	-	-	-	-	-	-	-	-	459	459	457	291	
80-75	L4	92	1.5	RABBIT	-	-	-	-	-	-	-	-	-	-	-	-	459	459	457	291	
78-75	L4	92	1.5	SCIROCCO	-	-	-	-	-	-	-	-	-	-	-	-	459	459	457	291	
<b>VOLVO</b>																					
75-70	L6	183	3.0	164	401	402	403	512	512	514	676	677	678	N/R		459	457	1040	291		
07-92	L6	178	2.9	ALL MODELS	401	402	403	512	512	514	676	677	678	N/R		459	457	1040	291		
03-99	L6	171	2.8	S80	401	402	403	512	512	514	676	677	678	N/R		459	457	1040	291		
89-87	V6	171	2.8	780	401	402	403	512	512	514	676	677	678	N/R		459	457	1040	291		
81-80	V6	171	2.8	262, 265	401	402	403	512	512	514	676	677	678	N/R		459	457	1040	291		
82-80	V6	171	2.8	264	401	402	403	512	512	514	676	677	678	N/R		459	457	1040	291		
89-83	V6	171	2.8	760	401	402	403	512	512	514	676	677	678	N/R		459	457	1040	291		
89-87	V6	171	2.8	780	401	402	403	512	512	514	676	677	678	N/R		459	457	1040	291		
79-76	V6	165	2.7	262, 264, 265	401	402	403	512	512	514	676	677	678	N/R		459	459	457	291		
07-05	L5	151	2.5	S40	401	402	403	512	512	514	676	677	678	N/R		459	459	457	291		
07-03	L5	151	2.5	S60	401	402	403	512	512	514	676	677	678	N/R		459	459	457	291		
07-05	L5	151	2.5	S80	401	402	403	512	512	514	676	677	678	N/R		459	459	457	291		
05-03	L5	151	2.5	V70	401	402	403	512	512	514	676	677	678	N/R		459	459	457	291		
07-03	L5	151	2.5	XC70	401	402	403	512	512	514	676	677	678	N/R		459	459	457	291		
05-03	L5	151	2.5	XC90	401	402	403	512	512	514	676	677	678	N/R		459	459	457	291		
05-98	L5	146	2.4	V70	401	402	403	512	512	514	676	677	678	N/R		-	-	-	-		
05-98	L5	146	2.4	C70	401	402	403	512	512	514	676	677	678	N/R		-	-	-	-		
07-05	L5	146	2.4	S40	401	402	403	512	512	514	676	677	678	N/R		-	-	-	-		
07-01	L5	146	2.4	S60	401	402	403	512	512	514	676	677	678	N/R		-	-	-	-		
00-98	L5	146	2.4	S70	401	402	403	512	512	514	676	677	678	N/R		-	-	-	-		
97-93	L5	146	2.4	850	401	402	403	512	512	514	676	677	678	N/R		459	459	457	291		
85-83	L6	146	2.4	760	401	402	403	512	512	514	676	677	678	N/R		459	459	457	291		
86	L6	146	2.4	740	401	402	403	512	512	514	676	677	678	N/R		459	459	457	291		
85	L6	146	2.4	745	401	402	403	512	512	514	676	677	678	N/R		459	459	457	291		
84-82	L6	146	2.4	244	401	402	403	512	512	514	676	677	678	N/R		459	459	457	291		
84-82	L6	146	2.4	245	401	402	403	512	512	514	676	677	678	N/R		459	459	457	291		
81-80	L6	146	2.4	264, 265	401	402	403	512	512	514	676	677	678	N/R		459	459	457	291		
05-01	L5	140	2.3	S60	401	402	403	512	512	514	676	677	678	N/R		459	459	457	291		
05-98	L5	140	2.3	C70	401	402	403	512	512	514	676	677	678	N/R		-	-	-	-		
2000	L5	140	2.3	S70	401	402	403	512	512	514	676	677	678	N/R		-	-	-	-		
05-98	L5	140	2.3	V70	401	402	403	512	512	514	676	677	678	N/R		-	-	-	-		
97-94	L5	140	2.3	850	401	402	403	512	512	514	676	677	678	N/R		459	459	457	291		
95-91	L4	140	2.3	940	401	402	403	512	512	514	676	677	678	N/R		459	459	457	291		
93-90	L4	140	2.3	240	401	402	403	512	512	514	676	677	678	N/R		459	459	457	291		

(1) Remote filter mount kit is optional unless otherwise noted.

# TRANSMISSION/ENGINE OIL COOLERS

## Application Guide

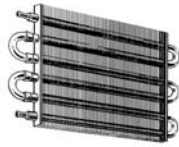

TRANS-COOLER®

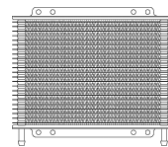

ENGINE OIL COOLERS

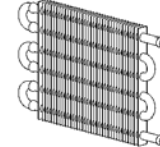

ULTRA-COOL®

HIGH PERFORMANCE

RAPID-COOL®

YEAR	TYPE	CID	ENGINE LITERS (VIN)	APPLICATION	ULTRA-COOL®			HIGH PERFORMANCE			RAPID-COOL®			REQUIRED TRANS FITTING KIT		REMOTE ENGINE KIT			
					LIGHT DUTY	MEDIUM DUTY	HEAVY DUTY	LIGHT DUTY	MEDIUM DUTY	HEAVY DUTY	LIGHT DUTY	MEDIUM DUTY	HEAVY DUTY	COOL NOTE	LIGHT DUTY	MEDIUM DUTY	HEAVY DUTY	(1)	COOLER NOTE
<b>VOLVO (Cont'd)</b>																			
92-85	L4	140	2.3	740	401	402	403	512	512	514	676	677	678	N/R		459	459	457	291
91-89	L4	140	2.3	780	401	402	403	512	512	514	676	677	678	N/R		459	459	457	291
90-84	L4	140	2.3	760	401	402	403	512	512	514	676	677	678	N/R		459	459	457	291
89-81	L4	140	2.3	244, 245	401	402	403	512	512	514	676	677	678	N/R		459	459	457	291
84-81	L4	140	2.3	242	401	402	403	512	512	514	676	677	678	N/R		459	459	457	291
84-81	L4	140	2.3	242	401	402	403	512	512	514	676	677	678	N/R		459	459	457	291
85	L4	140	2.3	745	401	402	403	512	512	514	676	677	678	N/R		459	459	457	291
84	L4	140	2.3	GLE	401	402	403	512	512	514	676	677	678	N/R		459	459	457	291
84-76	L4	128	2.1	242	401	402	403	512	512	514	676	677	678	N/R		459	459	457	291
85-76	L4	128	2.1	244, 245	401	402	403	512	512	514	676	677	678	N/R		459	459	457	291
81	L4	128	2.1	264	401	402	403	512	512	514	676	677	678	N/R		459	459	457	291
84	L4	128	2.1	DL	401	402	403	512	512	514	676	677	678	N/R		459	459	457	291
75	L4	122	2.0	242, 244, 245	401	402	403	512	512	514	676	677	678	N/R		459	459	457	291
74-69	L4	122	2.0	142, 144, 145	401	402	403	512	512	514	676	677	678	N/R		459	459	457	291
73-69	L4	122	2.0	1800	401	402	403	512	512	514	676	677	678	N/R		459	459	457	291
04-00	L4	116	1.9	S40, V40	401	402	403	512	512	514	676	677	678	N/R		459	459	457	291
68-62	L4	112	1.8	122	401	402	403	512	512	514	676	677	678	N/R		459	459	457	291
68-67	L4	112	1.8	142, 144, 145	401	402	403	512	512	514	676	677	678	N/R		459	459	457	291
68	L4	112	1.8	1800	401	402	403	512	512	514	676	677	678	N/R		459	459	457	291

(1) Remote filter mount kit is optional unless otherwise noted.